**Variable-Area Flowmeter
for Horizontal and Vertical Installation**

BGF

Device Description



Contents

1	Identification	4
1.1	Supplier/manufacturer	4
1.2	Product type.....	4
1.3	Product name.....	4
1.4	Issue date	4
1.5	Version no.....	4
2	Applications	4
3	Operational mode and system design	4
3.1	Measuring principle.....	4
3.2	System design	4
4	Input.....	4
4.1	Measured variable	4
4.2	Measuring range (lower-range and upper-range value)	4
4.3	Measuring range table	5
5	Output (electrical equipment, options)	5
5.1	Binary output.....	5
5.1.1	KEI 1 or KEI 2 limit transducers	5
5.1.2	KEM 1 or KEM 2 limit transducers (special version)	5
5.2	Analog output with the ES magneto-electric transmitter.....	5
5.3	ES with PROFIBUS PA output	5
5.4	Analog output with the KINAX 3W2 angle-of-rotation transmitter.....	6
6	Characteristic values	6
6.1	Accuracy	6
6.1.1	Reference conditions.....	6
6.1.2	Measured error	6
6.1.3	Repeatability.....	6
6.2	Influence of ambient temperature	6
6.3	Influence of ambient temperature	6
7	Conditions of use	6
7.1	Installation conditions	6
7.1.1	Mounting/start-up	7
7.1.2	Device settings	7
7.1.3	Adjusting the limit transducer	7
7.1.4	Operation in hazardous areas	8
7.2	Ambient conditions	8
7.2.1	Ambient temperature ranges.....	8
7.2.2	Storage temperature	8
7.2.3	Climatic category	8
7.2.4	Degree of protection.....	8
7.2.5	Shock resistance/vibration resistance	8
7.2.6	Electromagnetic compatibility.....	8
7.3	Fluid conditions	9
7.3.1	Fluid temperature ranges	9
7.3.2	D iagrams: Max. ambient temperature based on the fluid temperature for the ES	9
7.3.3	Fluid pressure limit	10
7.3.4	Inlet and outlet sections.....	10
7.3.5	Physical state	10
7.3.6	Density	10
7.3.7	Pressure (for gas measurement).....	10
8	Construction details.....	11
8.1	Type of construction/dimensions	11
8.1.1	Aluminum indicator housing	11
8.1.2	Dimension drawing for heating connection	11
8.1.3	Indicator housing made of stainless steel	12
8.2	Weight.....	12
8.3	Flange connections for the measuring element.....	12
8.4	Connections for heating jacket	12
8.5	Magnetic filter.....	13
8.6	Material	13
9	Electrical connection	14
9.1	Wiring diagram for ES transmitter (signal output 4-20 mA with HART®)	14
9.2	Wiring diagram for ES transmitter with 4-20 mA output and 2 limit transducers	14
9.3	Wiring diagram for ES transmitter with 4- 20 mA output, pulse output and limit transducer.....	15
9.4	Wiring diagram for inductive limit transducers	15
9.5	Wiring diagram for KINAX 3W2 transmitter with 4-20 mA output, 2 wires	16
9.6	Wiring diagram for KINAX 3W2 transmitter with 4-20 mA output, 3 wires	16
9.7	Wiring diagram for KINAX 3W2 transmitter with 4-20 mA output, 4 wires	17
9.8	Wiring diagram for KEM 1 and KEM 2 double-throw microswitches	17

10	Indicator unit	18
11	Auxiliary power	18
12	CE mark	18
13	Order information	18
13.1	Available accessories	18
14	Standards and directives, certificates and approvals	18
15	Replacement parts	18
16	Exploded views	19
16.1	Fitting with measuring body	19
16.1.1	BGF-.... standard version DN 15-25	19
16.1.2	BGF-.... standard version DN 50-80	19
16.2	Indicator unit	20
16.2.1	Complete indicator unit, local with scale	20
16.2.2	Complete indicator unit with 1 SJ 3,5 N limit transducer	20
16.2.3	Complete indicator unit with 2 SJ 3,5 N limit transducers.....	20
16.2.4	Complete indicator unit with E2 KINAX Ex transmitter	21
16.2.5	Complete indicator unit with E2 KINAX Ex transmitter and 1 SJ 3,5 N limit transducer.....	21
16.2.6	Indicator unit with transmitter type ES Ex HART®	21
17	EC Type Examination Certificate	22
18	Sales representatives	27
19	Notes	27

1 Identification

1.1 Supplier/manufacturer

Heinrichs Messtechnik GmbH
 Robert-Perthel-Str. 9 · D-50739 Köln
 Phone +49 (221) 49708 - 0
 Fax +49 (221) 49708 - 92
 Internet: <http://www.heinrichs-mt.com/>
 E-mail: <mailto:info@heinrichs-mt.com>

1.2 Product type

Mechanical flowmeter in all-metal design

1.3 Product name

BGF with subgroups
 BGF-S (stainless steel)
 BGF-P (PTFE)

1.4 Issue date

28/10/2003

1.5 Version no.

4.0
 File: BGF_GB_04_eng.doc

2 Applications

The BGF meter is suitable for flow measurement of liquid or gaseous products in pipes. **The special advantage is that it can be used for all directions of flow.** It shows the current flow rate in volume or mass per unit in time.

Applications: flow measurement, dosing, monitoring, adjusting and control of liquid and gaseous products. The meter's design makes it ideal for processes under difficult and adverse operating conditions.

The devices are available with additional electrical equipment for process monitoring and control.

3 Operational mode and system design

3.1 Measuring principle

The measuring element consists of a sharp-edged measuring ring and a conical measuring body with a compression spring.

If a medium flows with sufficient velocity through the measuring ring, the position of the measuring body will shift until the flow force and the measuring body plus the spring tension establish equilibrium.

The position of the measuring body in the measuring ring serves as the measure of the flow and is converted to a rotary motion by the permanent magnet embedded in the measuring body through a magnetic tracking system. It is then transmitted to the scale and the additional electrical equipment.

3.2 System design

The meter consists of a cylindrical fitting pipe with flange connections on both sides, a measuring ring firmly inserted in it and a vertically movable, conical measuring body.

The position of the measuring body resulting from the flow rate is converted to a rotary motion on the pointer axis of the analog indicator unit by the built-in permanent magnet through the magnetic tracking system.

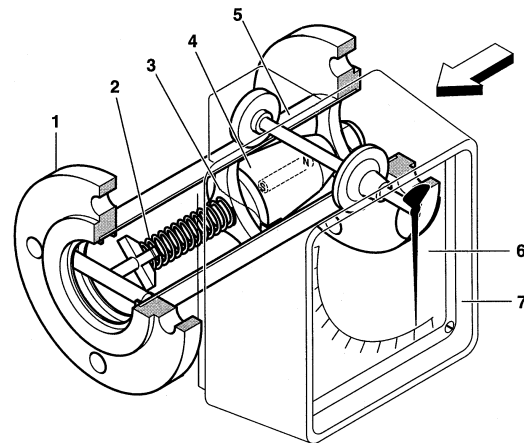

- 1 Fitting
- 2 Spring guide
- 3 Measuring ring
- 4 Measuring body
- 5 Magnet tracking system
- 6 Scale
- 7 Indicator unit

4 Input

4.1 Measured variable

Volume flow

4.2 Measuring range (lower-range and upper-range value)

Lower-range value	10% of lower-range value
Upper range value	100% of upper-range value
Measuring range span	10-100%
Smallest measuring range	16-160 l/h water
Largest measuring range	6000-60000 l/h water (standard version 1.4571)

4.3 Measuring range table

Measuring range table							
Nominal size (DN)	Measuring range	Measuring range for water at 1000 kg/m ³		Measuring range for air at 1.013 bars absolute pressure		Pressure loss (mbar)	Remarks
15	I	16 – 160	l/h	0.5 – 4.6	m ³ /h	110	1)
	J	25 – 250	l/h	0.7 – 7.0	m ³ /h	110	1)
	K	40 – 400	l/h	1.0 – 11	m ³ /h	110	1)
	L	60 – 600	l/h	1.7 – 17	m ³ /h	120	1)
25	I	16 – 160	l/h	0.5 – 4.6	m ³ /h	110	1)
	J	25 – 250	l/h	0.7 – 7.0	m ³ /h	110	1)
	K	40 – 400	l/h	1.0 – 11	m ³ /h	110	1)
	L	60 – 600	l/h	1.7 – 17	m ³ /h	120	1)
	M	100 – 1000	l/h	3 – 30	m ³ /h	90	1)
	N	160 – 1600	l/h	4 – 46	m ³ /h	105	1)
	P	250 – 2500	l/h	7 – 70	m ³ /h	130	1)
	Q	400 – 4000	l/h	11 – 110	m ³ /h	240	1)
40 Special version	P	250 – 2500	l/h	7 – 70	m ³ /h	75	1)
	Q	400 – 4000	l/h	11 – 110	m ³ /h	110	1)
	R	600 – 6000	l/h	17 – 170	m ³ /h	130	1)
50	Q	400 – 4000	l/h	11 – 110	m ³ /h	100	1)
	R	600 – 6000	l/h	17 – 170	m ³ /h	110	1)
	S	1000 – 10000	l/h	29 – 290	m ³ /h	120	1)
	T	1600 – 16000	l/h	46 – 460	m ³ /h	130	1)
	U	2500 – 25000	l/h	70 – 700	m ³ /h	200	1)
80	T	1600 – 16000	l/h	46 – 460	m ³ /h	110	1)
	U	2500 – 25000	l/h	70 – 700	m ³ /h	130	1)
	V	4000 – 40000	l/h	110 – 1100	m ³ /h	200	1)

1) with PP/PTFE magnet holder

5 Output (electrical equipment, options)

5.1 Binary output

Using the segments of the slot-type initiators or the eccentric discs of the microswitches, any switching point between 10% and 90% of the flow rate can be set.

5.1.1 KEI 1 or KEI 2 limit transducers

1 or 2 limit transducers
type SJ 3,5N, make Pepperl+Fuchs
(special switch possible, e.g. SN version)
Safety class: PTB Nr. 99 ATEX 2219 X
PTB Nr. 00 ATEX 2048 X

5.1.2 KEM 1 or KEM 2 limit transducers (special version)

Double-throw microswitches whose switching point is activated by a cam plate.

KEM 1 = 1 Double-throw microswitch
KEM 2 = 2 Double-throw microswitches

Maximum switching capacity:

230 VAC 50/60Hz 6 A
24 VDC 0.5 A
110 VDC 0.2 A

5.2 Analog output with the ES magneto-electric transmitter

The magneto-electric transmitter is factory-calibrated to the scale values upon shipment. The signal output is supplied exclusively in a two-wire connection at 4-20 mA. The 4-20 mA signal has the HART® protocol.

Additional options: 2 limit values, alternatively 1 limit value and 1 pulse output

The signal output and the limit values can be configured using a HART® modem operating on the following configuration programs: SensorPort from Bopp & Reuther, PDM from Siemens or AMS from Rosemount. Furthermore, a HART® hand-held terminal (with DD software) can also be used. For more information about configuration, please refer to the separate Operating Instructions for the ES.

Safety class: DMT 00 ATEX 075 / II2G EEx ia IIC T6

When installing electrical equipment in hazardous areas, the conditions and provisions specified in the approval documents must be followed.

5.3 ES with PROFIBUS PA output

The ES transmitter is available in the PROFIBUS PA version under the ES-PPA type designation. For operation details, see the separate ES-PPA Operating Instructions.

5.4 Analog output with the KINAX 3W2 angle-of-rotation transmitter

The signal output of the angle-of-rotation transmitter is factory-calibrated to the scale values. The signal output is 4-20 mA in 2-wire connection; or alternatively 0-20 mA in 4- or 3-wire connection. The signal output of 4 mA corresponds to the flow rate scale value of 0 (0 mA for the 0-20 mA version). 5.6 mA corresponds to 10% of the flow rate scale value (2 mA). 20 mA corresponds to 100% of the flow rate scale value.

Use in hazardous areas:

The angle-of-rotation transmitter is a component approved for hazardous areas. When used in hazardous areas, all the values and instructions indicated in the certificate of approval must be observed. Auxiliary power is fed through an approved intrinsically safe circuit of 12-30 V. To prove intrinsic safety, only authorized electrical equipment may be interconnected. Please take note of the maximum permissible ambient temperature of 60°C/75°C for the transmitter and the process temperature.

Safety class:

PTB 97 ATEX 2271 / II 2G EEx ia IIC T6

6 Characteristic values

6.1 Accuracy

6.1.1 Reference conditions

Water 20°C

6.1.2 Measured error

BGF-S/P +/- 2.0 % of URV for local display
(URV = upper-range value)

Additional inaccuracy for:

ES = +/- 0.2%

KINAX 3W2 = +/- 0.5%

6.1.3 Repeatability

+/- 0.8 % of URV

6.2 Influence of ambient temperature

- Without electrical equipment and with limit transducer without influence
- With KINAX 3W2 transmitter:
+/- 0.2 % / 10 K reference temperature 23°C
- With ES transmitter:
+/- 0.5 % / 10 K reference temperature 22°C

6.3 Influence of ambient temperature

Deviations in fluid temperature from the temperature observed during calibration can result in a proportional display fault because of the corresponding change in density. Changes in viscosity cause a non-linear display fault..

7 Conditions of use

The VDI/VDE guidelines 3513, Sheet 3, must be observed.

The meter is suitable for:

- Liquids with sufficient flow ability that are free of solids, do not bond and do not tend to settle.
- Gases with linear flow behavior and an adequate inlet pressure.

Viscosity factors will not be considered by the system.

7.1 Installation conditions

Vertical or horizontal installation, according to the direction of flow specified in the order.

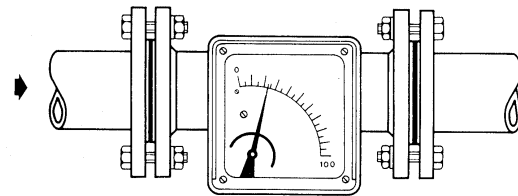

Durchfluß: waagrecht; links – rechts

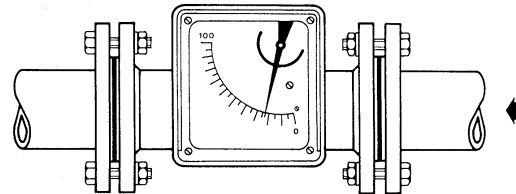

Durchfluß: waagrecht; rechts – links

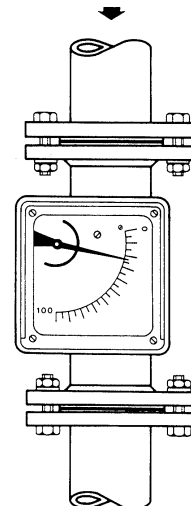

Durchfluß: senkrecht; von oben nach unten

When mounting the device in the horizontal position, make sure the indicator unit is not pointing upwards. This is to prevent water lodging on the glass window and entering the device under the protective shroud of the housing.

The limit values for temperature and air humidity at the mounting location must be maintained. Avoid corrosive atmospheres. If this cannot be avoided, ventilation must be installed.

Please make sure that there is adequate clearance from parts that might cause magnetic interferences such as solenoid valves and ferromagnetic components like steel brackets/supports. We recommend that the minimum lateral distance between two adjacently mounted devices be **300 mm**. The devices can be mounted close together if vertically offset by one device length. The minimum lateral clearance for interfering steel parts should be **200 mm**. In case of doubt, check the interference by moving the device back and forth in the selected distance by about 200 mm and testing whether the pointer position changes.

Select the mounting location so as to enable a reliable reading of the scale values. Please take note as well of the space requirement for any possible disassembly of the

device. As a rule, inlet and outlet sections in front of and behind the device are unnecessary if the medium has a linear flow profile. Avoid mounting accessories converging on one side in front of the device. However, if this is indispensable maintain a minimum device length of 250 mm as an inlet section.

The nominal size of the pipes to be connected must correspond to that of the meter. Avoid fittings converging on one side directly in front of the device. As a rule, install valves behind the measuring equipment if there are gases involved.

7.1.1 Mounting/start-up

Before installation check whether the measuring element is free from foreign bodies. The instrument must be mounted vertically or horizontally according to the planned and confirmed direction of flow.

The nominal size of the device and that of the pipes must be the same. The pressure stages and, hence, the dimensions of the flanges must coincide. The surface roughness of the flange sealing surface must be suitable for the prescribed gaskets.

Please check whether possible accessories like spring stops, gas/viscous-type damping sets are still correctly sitting on the flange. Check whether the mounting clearance between the flanges of the pipes corresponds to the assembly dimension of the device plus two gaskets. To achieve stress-free mounting, the flanges of the pipes must be aligned parallel to each other.

Use connecting bolts and gaskets in the prescribed dimensions. The gaskets must be suitable for the operating pressure, the temperature and the measured medium. With PTFE-coated devices, use gaskets whose interior and exterior diameter correspond to the sealing strip of the device.

Tighten the screws crosswise so that the process connections are tight. See to the tightening torques of screws especially with PTFE-coated devices.

The maximum torques for PTFE-coated devices are: DN15/DN25 = 14 Nm/DN50 = 25 Nm/DN80 = 35 Nm/DN100 = 42 Nm (following VDI/VDE Guideline 3513).

Please check whether the pipe is adequately stable so that vibration or swinging of the device is out of the question. (Do not use steel mounting parts on the device.)

When gas is used as the medium, pay special attention to the position of the valve. If the device is calibrated to more than 1.013 bars absolute pressure, the valve is usually installed behind the flowmeter. At 1.013 bars absolute pressure (free exhaust) install it in front of the device.

If there is risk of dirt or solid matter penetrating the process pipes, flush them beforehand so that these materials do not get caught in the device. Ferromagnetic solid matter such as spatter can lead to the breakdown of the device. If these materials are still present during normal operating conditions, mount a magnetic filter (accessory) in front of the device. When using liquids, flush to avoid a surge of gas bubbles. Slowly increase the supply pressure when using gases to prevent pressure surges. Basically, avoid activation using solenoid valves to prevent the measuring body from shooting upwards.

7.1.1.1 Gas measurement

When using gases, slowly let the operating pressure rise. At the same time, vary the operating pressure through a setting valve so that the measuring body is not knocked around since otherwise this would damage the measuring element.

7.1.2 Device settings

The measuring equipment is delivered ready for operation according to your order specifications. **The limit transducers** are set to the desired values. If you have submitted no requirements, the basic setting for

1 contact device: - Minimum contact switching point at 10% of descending flow (damped/closed-circuit principle).

2 contact devices: Minimum contact switching point at 10% of descending flow and maximum contact switching point at 90% of ascending flow.

7.1.3 Adjusting the limit transducer

The contacts are adjustable through the contact position indicators located on the scale. Dismantle the indicator cover, unfasten the contact position indicators, set to the desired value and reattach them.

7.1.4 Operation in hazardous areas

7.1.4.1 Without electrical equipment

The basic version of the flowmeter is a *non-electrical device* without its own ignition sources and meets DIN EN 13463-1 requirements. It can be used in hazardous areas that require Category 2 equipment.

Marking:  II 2GD c
Tech. File Ref. 03-02 X

Since the device does not have its own power sources that would result in a temperature increase, the fluid temperature is decisive for the maximum surface temperature.

When used in potentially explosive dust atmospheres, the device must be cleaned regularly in order to avoid deposits exceeding 5 mm.

7.1.4.2 With built-in electrical limit transducers

When the limit transducers are installed, the device becomes an electrical assembly and receives a marking in accordance with DIN EN 50014 from the entire device with the built-in electrical limit transducers.

The electrical and thermal data and the special conditions of the EC Type Examination Certificate of the built-in limit transducers must be observed (see also the diagram in Section 7.3.2).

The influence of the fluid temperature on the built-in limit transducers must be observed. The overtemperature of the maximum fluid temperature based on the maximum ambient temperature must be considered with a factor according to the following table:

Nominal size	Factor for standard version	Factor for the device with the indicator pulled forward
DN15 and DN25	0.2	0.07
DN40 and DN50	0.25	0.085
DN80 and DN100	0.3	0.1

Example for built-in limit transducer for DN 15 and DN 25:

Max. ambient temperature $T_{amb} = 40^{\circ}C$
 Max. fluid temperature $T_m = 120^{\circ}C$
 Factor for brought-in heat $F = 0.2$
 Temperature class T4

$T_{\ddot{u}}$ = Overtemperature
 T_a = Ambient temperature of limit transducer

$T_{\ddot{u}} = T_m - T_{amb} = 120^{\circ}C - 40^{\circ}C = 80^{\circ}C$
 $T_a = T_{\ddot{u}} * F + T_{amb} = 80^{\circ}C * 0,2 + 40^{\circ}C = 56^{\circ}C$

In accordance with the tables in the PTB 99 ATEX 2219 X EC Type Examination Certificate, the SJ 3,5-... N... inductive sensor must be operated in the T5 temperature class with an intrinsically safe circuit that does not exceed the maximum values of the Type 3 circuit.

When using the device in hazardous areas, follow the applicable national installation rules.

Example for calculating the max. fluid temperature based on the max. ambient temperature for the built-in sensor Type ES for DN 15/25.

$T_a = 70^{\circ}C$
 $T_{amb} = 60^{\circ}C$
 $F = 0,2$

$T_m = \left(\frac{T_a - T_{amb}}{F} \right) + T_{amb} = \left(\frac{70^{\circ}C - 60^{\circ}C}{0,2} \right) + 60^{\circ}C = 110^{\circ}C$

7.1.4.2.1 Marking for the device when the SJ 3,5-...N... limit transducer is built in

 PTB 99 ATEX 2219 X
II 2G EEx ia IIC T6-T4

7.1.4.2.2 Marking for the device when the ES magneto-electric transmitter is built in

 DMT 00 ATEX 075
II2G EEx ia IIC T6

7.1.4.2.3 Marking for the device when the KINAX 3W2 angle-of-rotation transmitter is built in

 PTB 97 ATEX 2271
II 2G EEx ia IIC T6

7.2 Ambient conditions

7.2.1 Ambient temperature ranges

Without electrical accessories:
 -40°C to +80°C
 With limit transducer:
 -40 °C to +65°C
 With KINAX signal output:
 -40°C to +60°C
 With ES signal output:
 -40°C to +70°C

For the hazardous area version, take note of the maximum ambient temperatures depending on the temperature class as specified in the Type Examination Certificate.

7.2.2 Storage temperature

The storage temperatures are identical to the ambient temperature ranges.

7.2.3 Climatic category

Weather-protected and/or unheated locations, class C according to IEC 654 Part 1

7.2.4 Degree of protection

IP 65

7.2.5 Shock resistance/vibration resistance

The meter should be protected from extreme shocks and vibrations, which could cause damage.

7.2.6 Electromagnetic compatibility

EN 61000-6-2:1999 Immunity industrial environment
 EN 50081-1 Emitted interference residential environment
 EN 55011:1998+A1:1999 Group 1, Class B
 NAMUR recommendation NE 21

BGF-P****P* -20°C to 125°C
 BGF-P****K* -0°C to 80°C

7.3 Fluid conditions

7.3.1 Fluid temperature ranges

Type	Fluid temperature
BGF-S****S*	-40°C to 350°C
BGF-S****P*	-20°C to 125°C
BGF-S****K*	-0°C to 80°C

The effect of the fluid temperature on the indicator unit and its built-in components must be considered. A pulled-forward indicator unit is necessary if the fluid temperature rises above 200°C.

7.3.2 Diagrams: Max. ambient temperature based on the fluid temperature for the ES

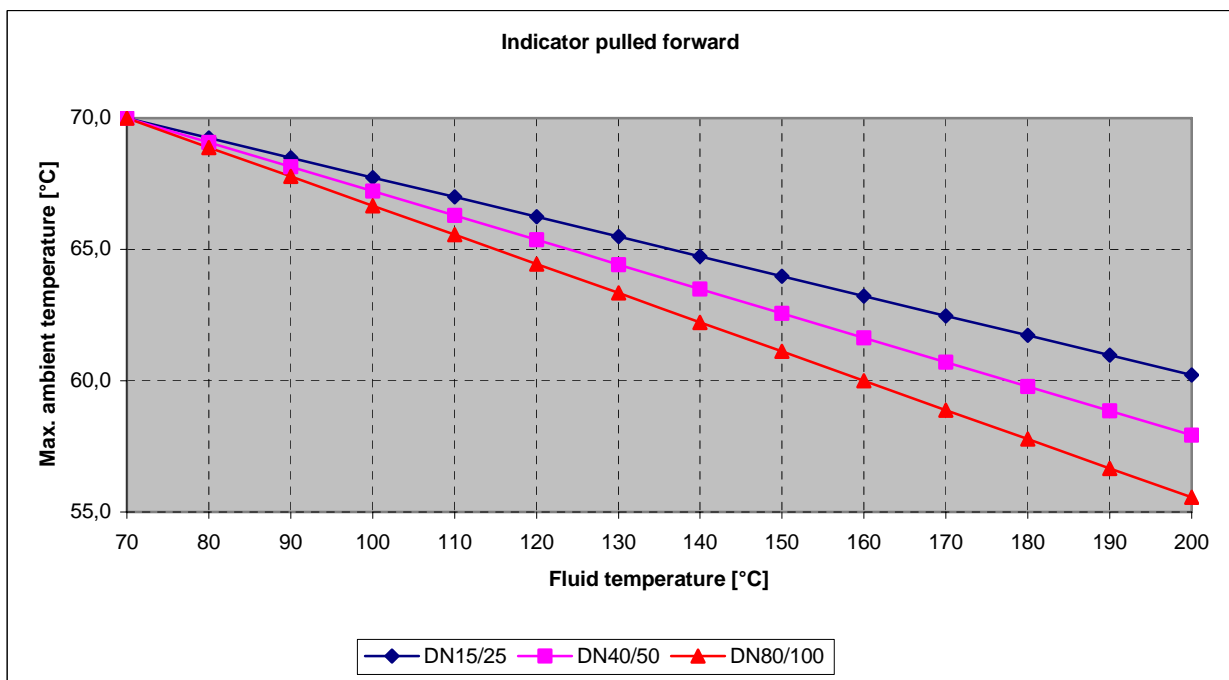
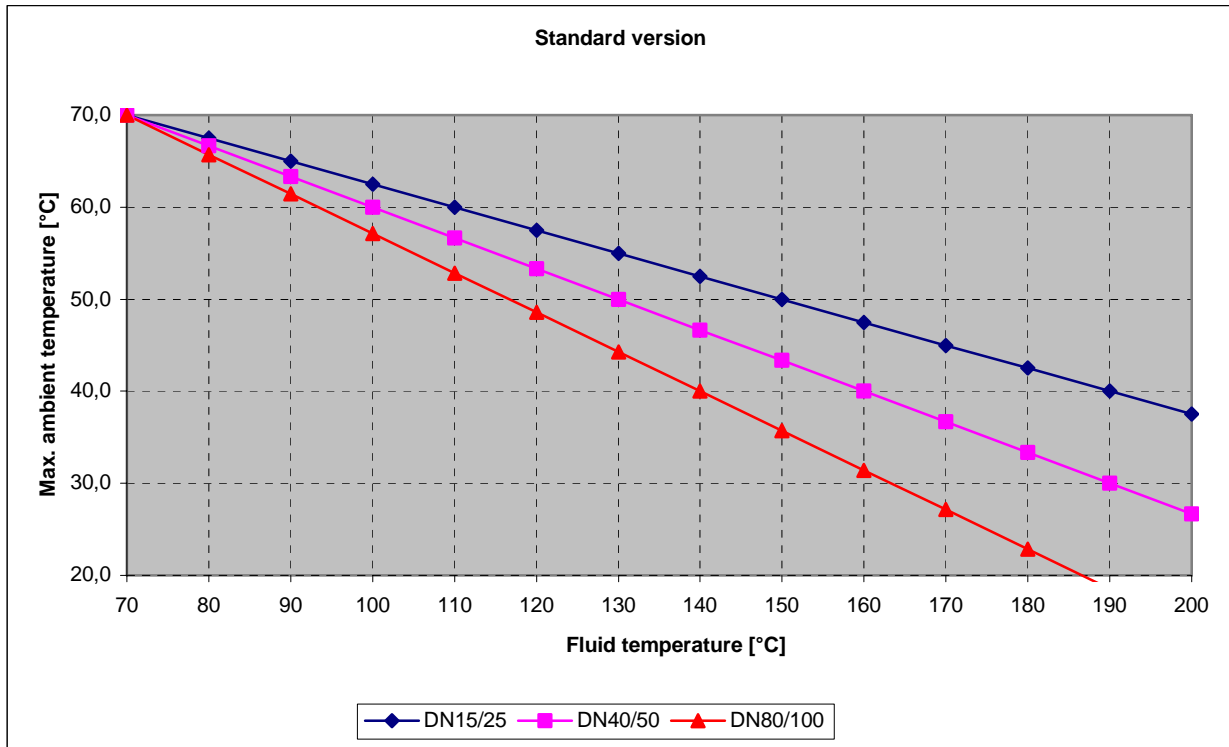

7.3.3 Fluid pressure limit

Standard version: BGF-S DN 15/25/40/50/80 PN 40
BGF-P DN 15/25/50/80 PN 16

Special version: BGF-S up to PN 400

7.3.4 Inlet and outlet sections

Inlet and outlet sections are not required for a linear flow profile of the fluid. For an extremely non-linear flow profile (e.g. shut-off/control valves are located in front of the meter), we recommend an inlet section with a mounting length of 250 mm (see also guidelines in accordance with VDI/VDE 3513).

7.3.5 Physical state

Liquid or gaseous

7.3.6 Density

Liquids: up to 2.0 kg/l
Gases: no restrictions

7.3.7 Pressure (for gas measurement)

The measured values only apply to the calibrated fluid data stated on the scale. Any change or deviation in pressure causes a display fault in gases. Viscosity factors cannot be considered by the system.

Pressure loss: Depends on the device size and the measuring range (see Measuring range table).

8 Construction details

The two main parts of the flowmeter are the valve with the measuring element and the indicator unit. A heating or cooling jacket can be added to the fitting.

8.1 Type of construction/dimensions

8.1.1 Aluminum indicator housing

Direction of flow: from the top to the bottom

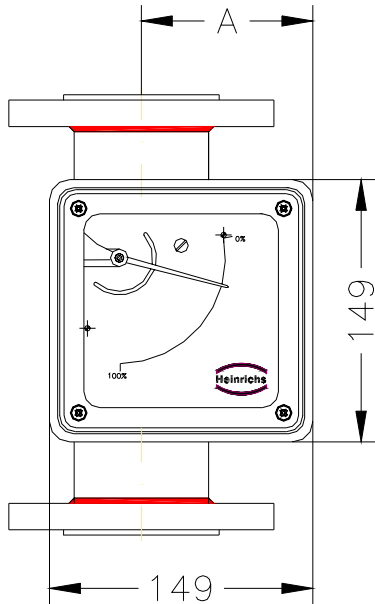

8.1.2 Dimension drawing for heating connection

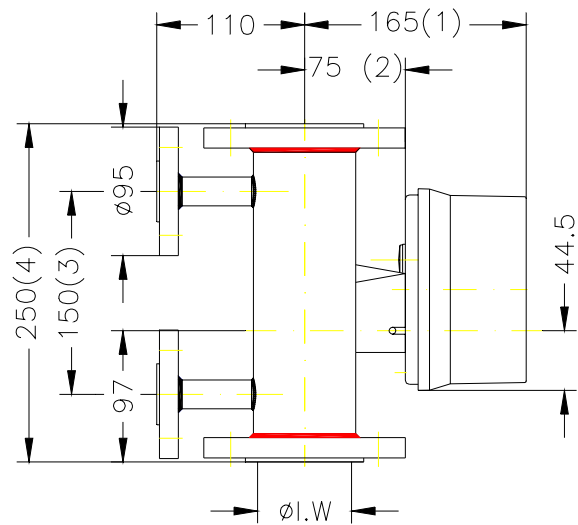

Deviating mounting dimensions:

- (1) 265 mm with the indicator unit pulled forward
- (2) 175 mm with the indicator unit pulled forward
- (3) For special design DN 100 120 mm
- (4) With preceding magnetic filter, 50 mm longer plus 2 gaskets

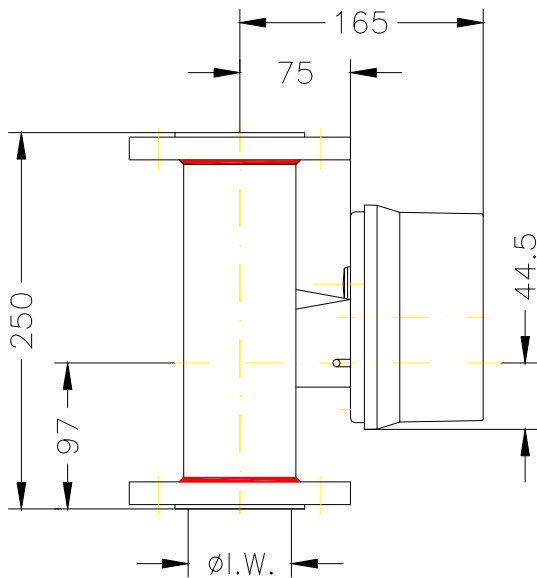

Dimensions:

DN	PN	Inside diameter	A
15	40	26	74
25	40	32	77
40	40	46	88
50	40	70	97
80	16	102	113

8.1.3 Indicator housing made of stainless steel

Direction of flow: from the top to the bottom

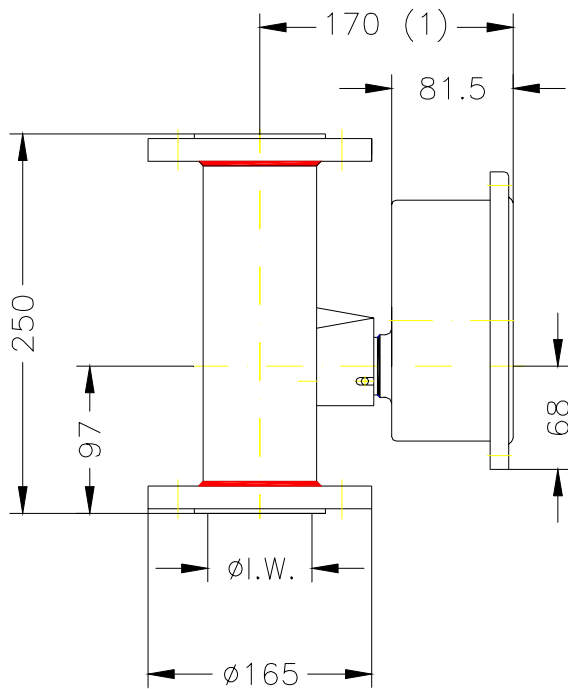
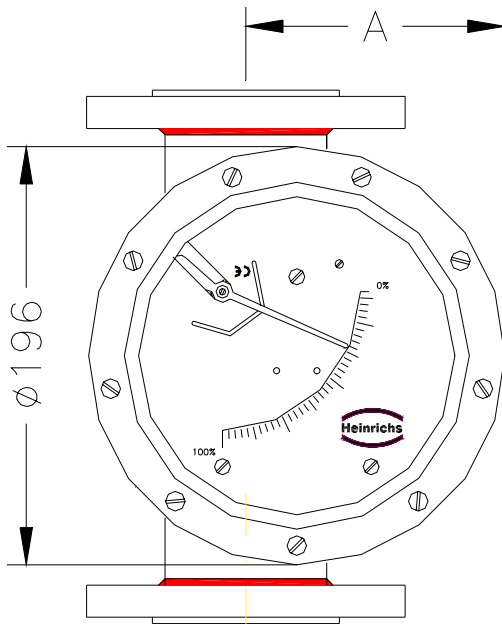

DN	PN	Inside diameter	A
15	40	26	100
25	40	32	103
40	40	46	110
50	40	70	122
80	16	102	138

Deviating mounting dimensions:

- (1) 265 mm with the indicator unit pulled forward

8.2 Weight

DN	Approximate weight kg
15	4
25	5
40	6,9
50	9,3
80	12,8

Nominal size	Weight [kg]
¾", 150 lbs, ANSI B16.5	3
1", 150 lbs, ANSI B16.5	4,2
1 ½", 150 lbs, ANSI B16.5	6
2", 150 lbs, ANSI B16.5	7,5
3", 150 lbs, ANSI B16.5	13

Nominal size	Weight [kg]
¾", 300 lbs, ANSI B16.5	3.4
1", 300 lbs, ANSI B16.5	4.7
1 ½", 300 lbs, ANSI B16.5	6.8
2", 300 lbs, ANSI B16.5	8.5
3", 300 lbs, ANSI B16.5	14.5

8.3 Flange connections for the measuring element

The BGF series can be equipped with the following flanges:

Fitting	Flange
DN 15	DN 15 PN 40 Form C DIN 2501 DN 15 PN 40 Form N DIN 2512 ¾" 150 lbs RF ANSI B16.5 ¾" 300 lbs RF ANSI B16.5 ¾" 300 lbs RTJ ANSI B16.5
DN 25	DN 25 PN 40 Form C DIN 2501 DN 25 PN 40 Form N DIN 2512 1" 150 lbs RF ANSI B16.5 1" 300 lbs RF ANSI B16.5 1" 300 lbs RTJ ANSI B16.5
DN 50	DN 50 PN 40 Form C DIN 2501 DN 50 PN 40 Form N DIN 2512 2" 150 lbs RF ANSI B16.5 2" 300 lbs RF ANSI B16.5
DN 80	DN 80 PN 40 Form C DIN 2501 DN 80 PN 40 Form N DIN 2512 3" 150 lbs RF ANSI B16.5 3" 300 lbs RF ANSI B16.5

Special flanges can be supplied on request.

8.4 Connections for heating jacket

Pipe for	Ermeto 12 mm
Flange in acc. with DIN	DN 15 or DN 25 PN 40
Flange in acc. with ANSI	½" 150 lbs

The DN 25 flange is a special version.

8.5 Magnetic filter

The BGF flowmeter is sensitive to impure media. Before installing the device, clean the pipes of dirt, spatter and other foreign matter. If the medium comes with solid particles, connect a suitable filter in series. When dealing with flow media with ferrous particles, we recommend the connection of a magnetic filter.

To protect both magnetic filter types, MF-S (stainless steel) and MF-P/S (PTFE/stainless steel), from corrosion, encapsulated permanent magnets are laid out in spiral form. The spiral mounting produces optimum effect at small pressure loss. The filter can be supplied with groove or tongue, projection or return, other standards or special connections according to customer wishes.

Dimensions:

DN	g (mm)
15	45
25	68
40	88
50	102
65	122
80	138

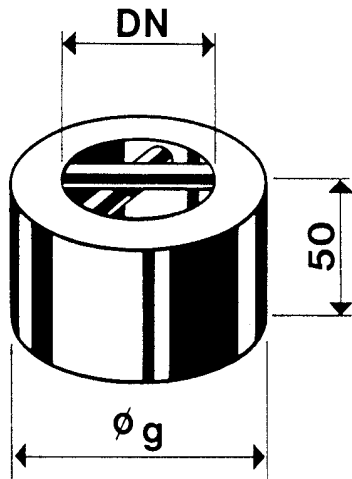

BGF flowmeter with preceding magnetic filter (1)

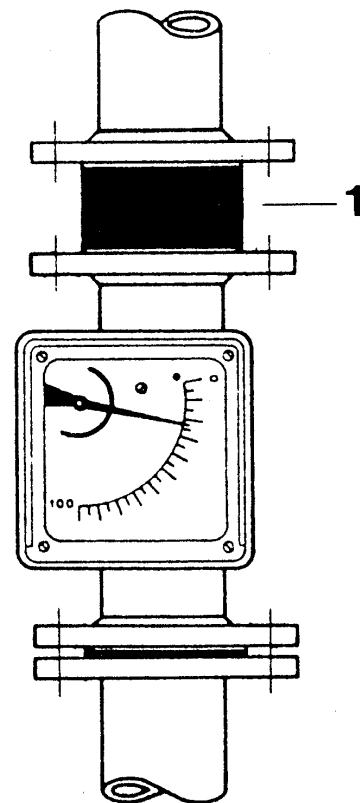
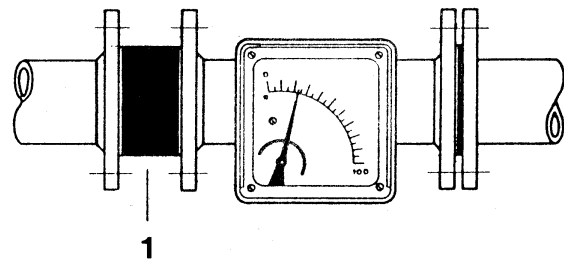

8.6 Material

Fitting

Type		Measuring tube	Lining of measuring tube	Flanges	Flange lining	Measuring body	Resetting spring
BGF – S	Standard ≤ 80°C	Stainless steel	Stainless steel	Stainless steel	none	PP	Stainless steel
	Fluid ≤ 125°C	Stainless steel	Stainless steel	Stainless steel	none	PTFE	Stainless steel
		Stainless steel	Stainless steel	Stainless steel	none	Stainless steel	Stainless steel
BGF – P		Stainless steel	PTFE	Stainless steel	PTFE	PTFE	

Indicator unit

Type	Base plate	Housing
BGF – S/P	Aluminum	Aluminum, safety glass window
Optional	Stainless steel	Stainless steel, safety glass window

9 Electrical connection

Wiring

To connect the auxiliary power, remove the indicator cover, insert the connector cable into the cable gland and attach it to the terminals according to the terminal diagram. Tighten the cable gland securely, remount the indicator cover and close it tightly.

9.1 Wiring diagram for ES transmitter (signal output 4-20 mA with HART®)

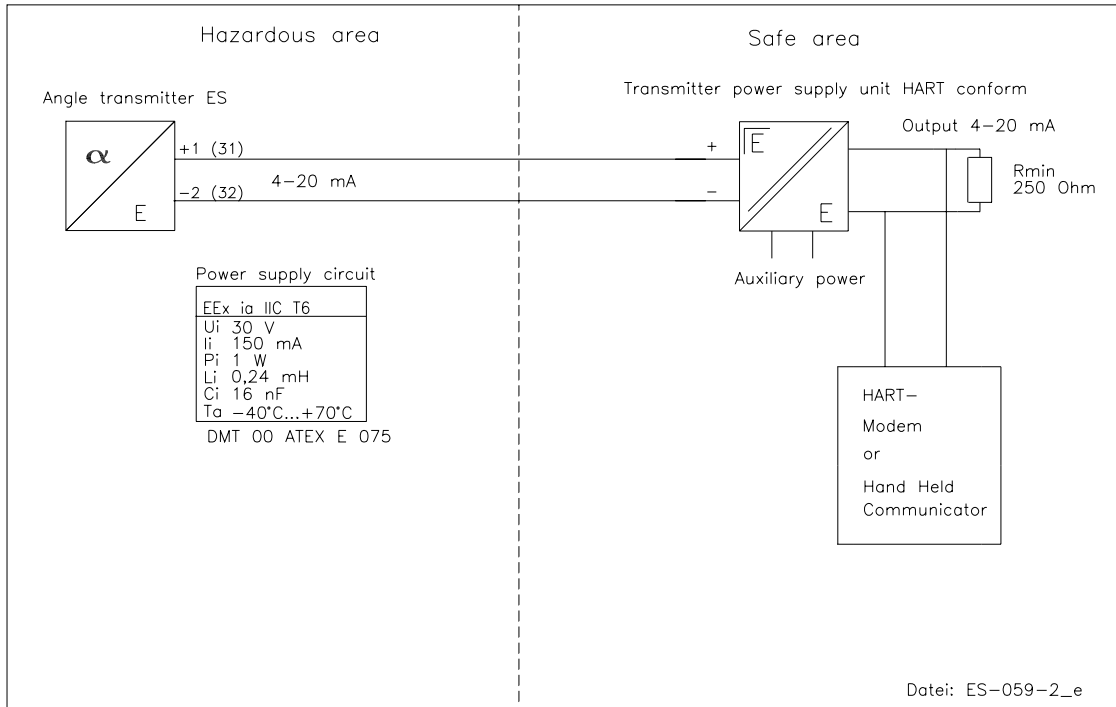

9.2 Wiring diagram for ES transmitter with 4-20 mA output and 2 limit transducers

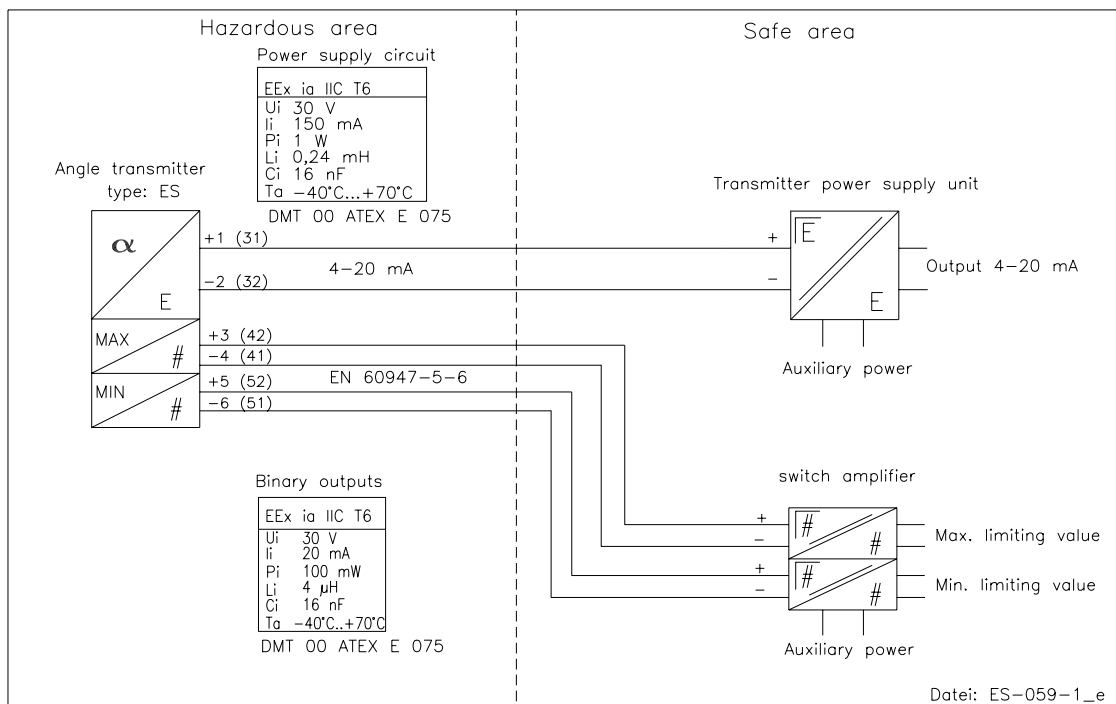

9.3 Wiring diagram for ES transmitter with 4-20 mA output, pulse output and limit transducer

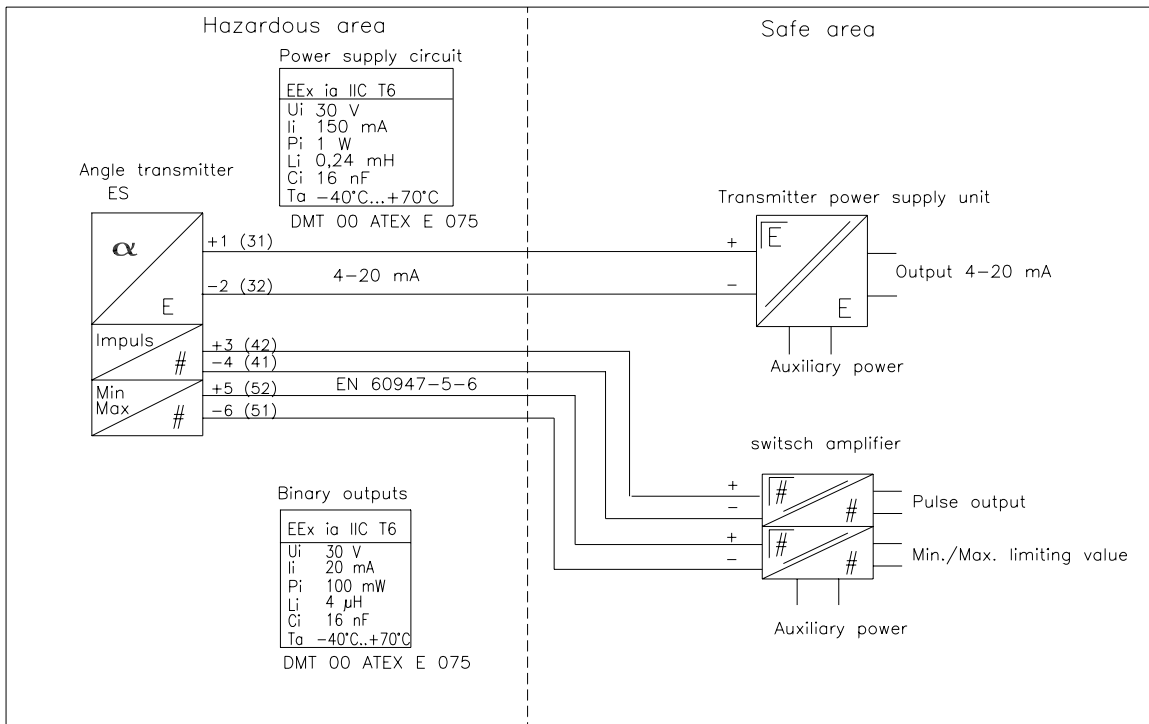

9.4 Wiring diagram for inductive limit transducers

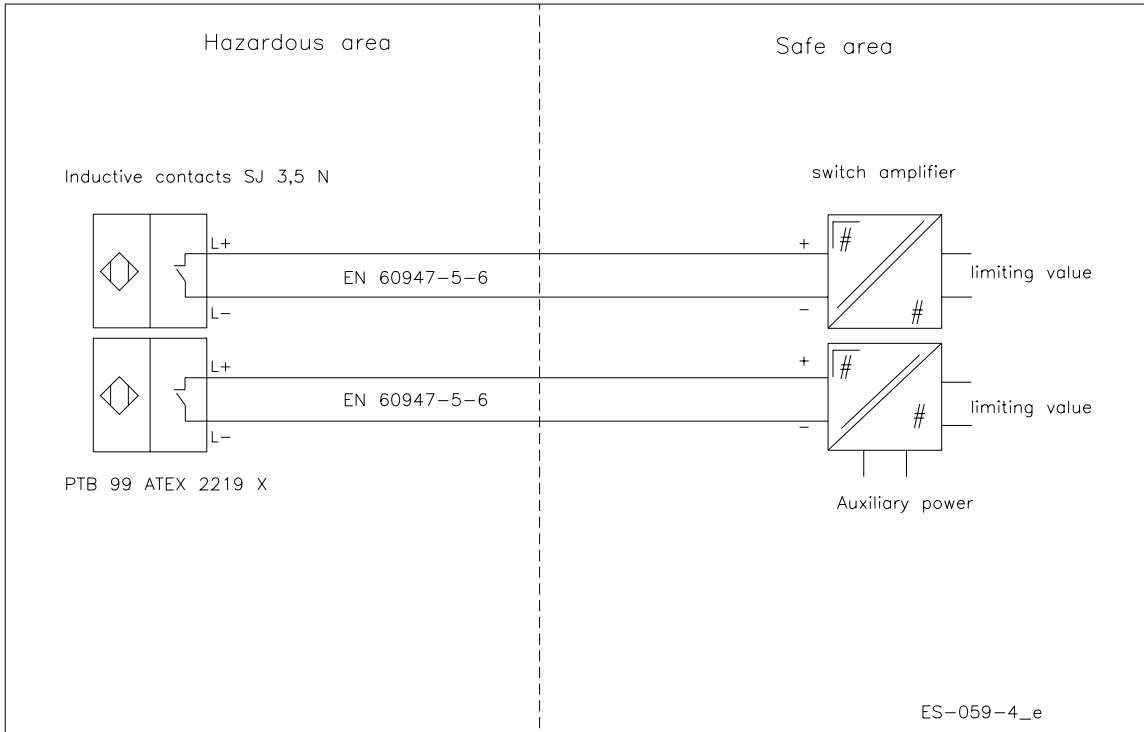

9.5 Wiring diagram for KINAX 3W2 transmitter with 4-20 mA output, 2 wires

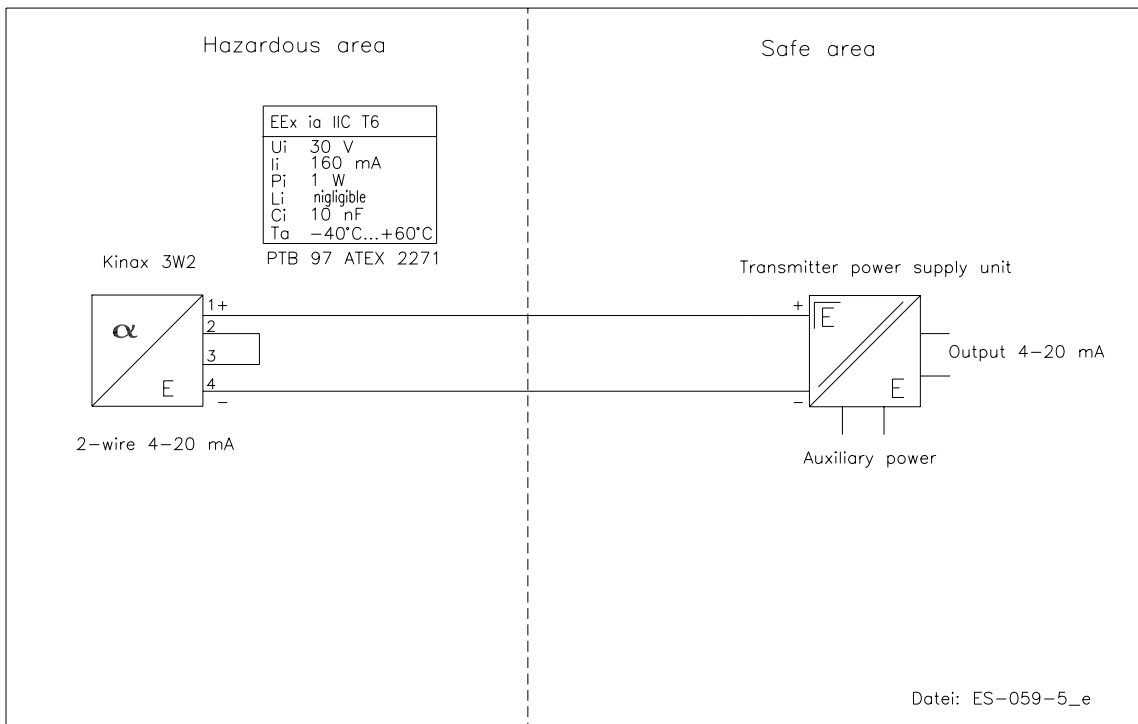

9.6 Wiring diagram for KINAX 3W2 transmitter with 4-20 mA output, 3 wires

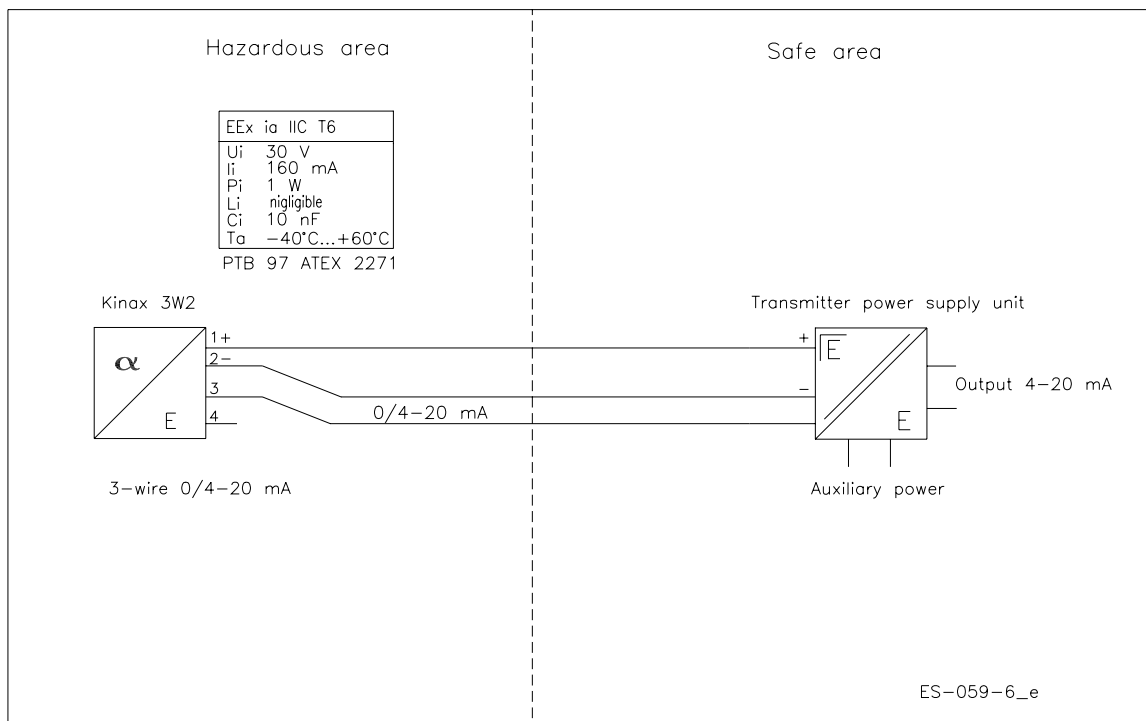

9.7 Wiring diagram for KINAX 3W2 transmitter with 4-20 mA output, 4 wires

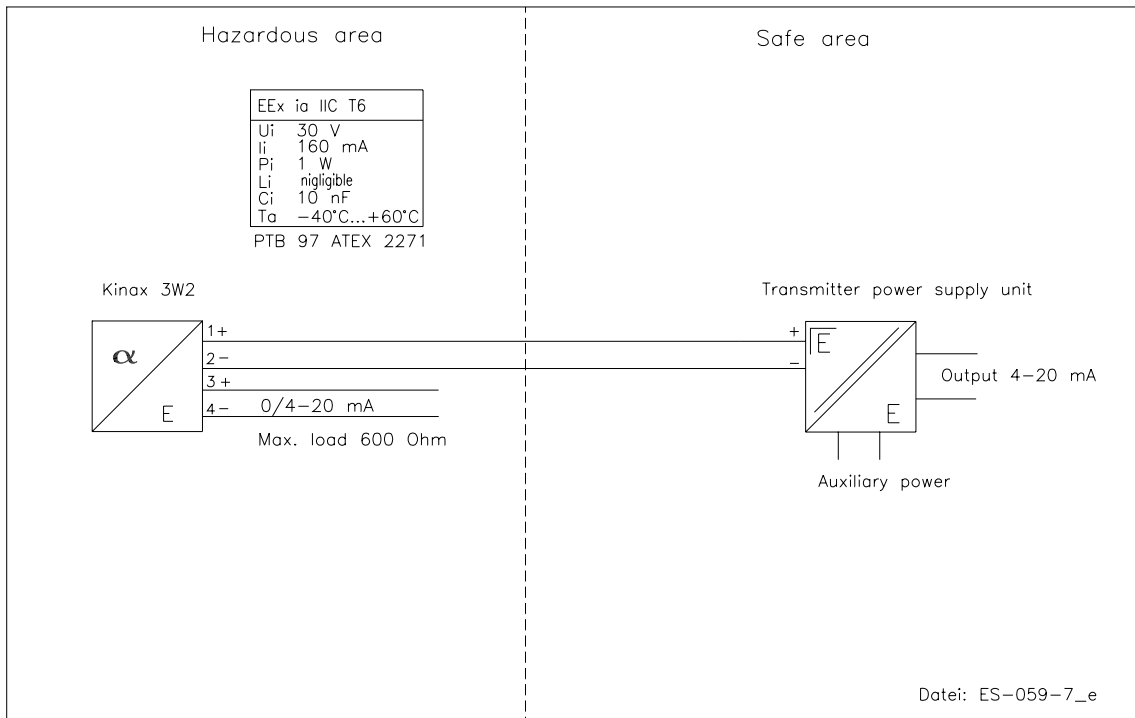

9.8 Wiring diagram for KEM 1 and KEM 2 double-throw microswitches

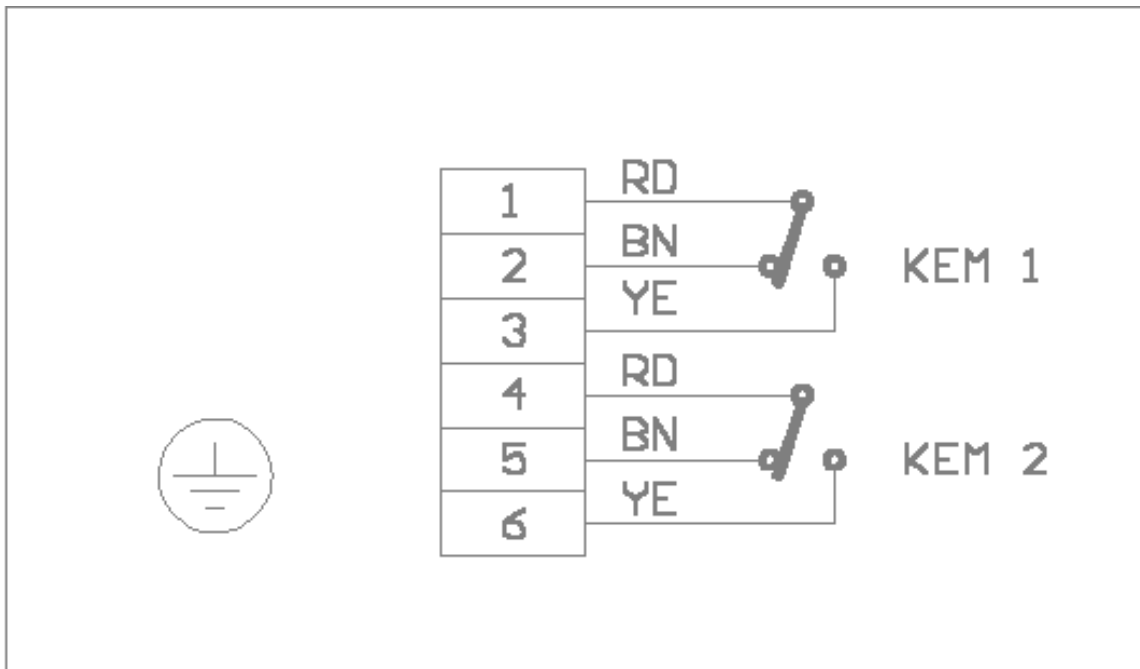

10 Indicator unit

- Analog indicator approx. 90° with pointer
- Customized product scale
- ES transmitter with freely programmable user interface
- Parameters may be changed based on the ES Operating Instructions.

11 Auxiliary power

see Electrical connection

12 CE mark

The measuring system meets the statutory requirements of the following EU directives: Directive 94/9/EC (Equipment and Protective Systems for Use in Potentially Explosive Atmospheres), the Electromagnetic Compatibility (EMC) Directive 89/336/EEC and the Pressure Equipment Directive 97/23/EC.

Heinrichs Messtechnik confirms compliance with the directives by attaching the CE mark.

13 Order information

Please include the following information in your order: product data, specific weight, temperature, pressure, viscosity, material design, connection size, measuring range, direction of flow, desired accessories, required approvals and material certificates. **See Device selection by model code.**

13.1 Available accessories

- Stainless steel indicator unit, glass window IP 66
- Indicator unit for high or low temperatures pulled forward by 100 mm
- Fitting with heating or cooling jacket (with Ermeto or flange connection)
- 1 or 2 inductive limit transducers
- KINAX or ES electric transmitter
- Drainable fitting (pump has been disconnected)
- Magnetic filter
- PROFIBUS PA

14 Standards and directives, certificates and approvals

- Certified to DIN-EN 9001
- Production in accordance with AD guidelines and HPO approval (TRB200/TRD201)
- TÜV approval for welding requirements in accordance with DIN-EN 729-2
- Measuring range rated and converted to other products according to VDE/VDI guidelines 3513
- Directive 94/9/EC (Equipment and Protective Systems for Use in Potentially Explosive Atmospheres)
- EN 50014:1997+A1-A2 - General requirements
- EN 50020:1994 - Intrinsic safety "i"
- Directive 89/336/EEC (EMC Directive)
- EN 61000-6-2:1999 – Immunity industrial environment
- EN 50 081-1 – Emitted interference residential environment
- EN 55011:1998+A1:1999 – Group 1, Class B
- NAMUR recommendation NE 21
- EN 60529 – Degrees of protection through housing (IP code)
- EN 61010 – Safety requirements for electrical measuring, control and laboratory devices
- EN 60947-5-6:2000 – Switchgear and controlgear
- Directive 97/23/EC (Pressure Equipment Directive)

15 Replacement parts

The following parts can be ordered as replacement parts:

- 1) Indicator cover with window/gasket/screws
- 2) Scale with standard scaling
- 3) Pointer
- 4) Limit value indicator
- 5) Pointer stop
- 6) Measuring body with guides and safety screws
- 7) Resetting spring
- 8) Limit value initiator

16 Exploded views

16.1 Fitting with measuring body

Name	Part no.
Fitting	1
Measuring body	2
Resetting spring	3

16.1.1 BGF-.... standard version DN 15-25

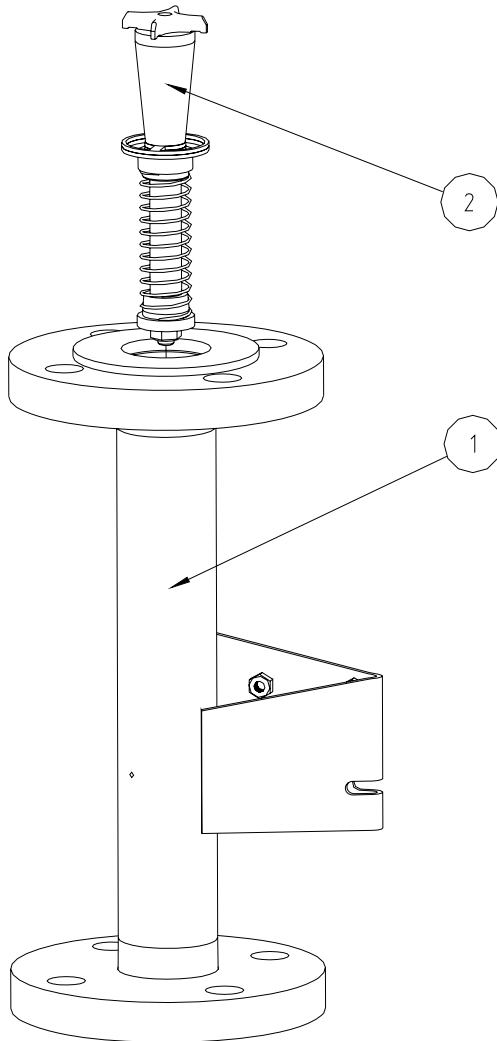

16.1.2 BGF-.... standard version DN 50-80

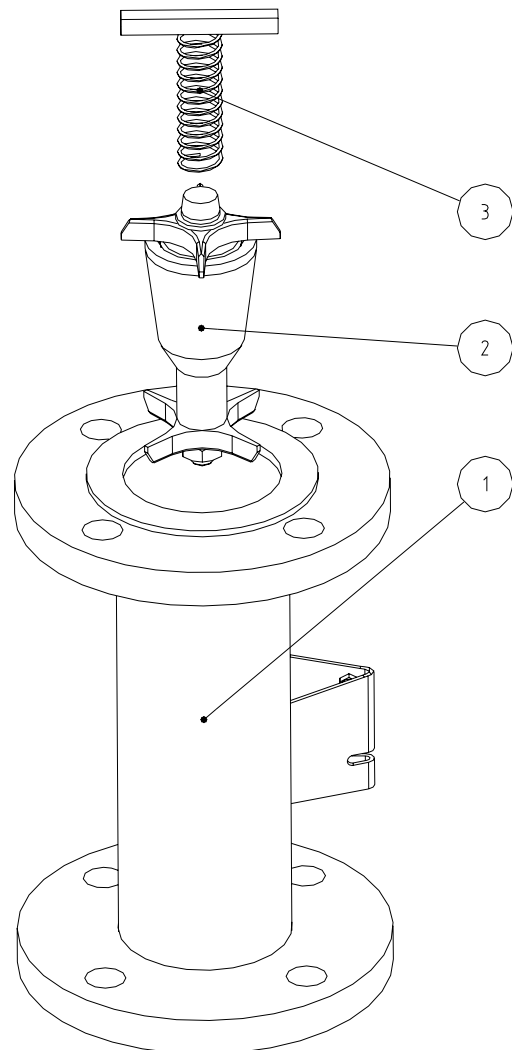

16.2 Indicator unit

Name	Part no.
Mounting plate with 1 thread M 20 x 1.5	10
Mounting plate with 2 threads M 20 x 1.5	11
Bearing unit	20
Fixing screws for bearing unit	30
Dummy plug M 20 x 1.5	40
Cable gland	41
Cable gland	42
Scale, blank	50
Scale, product scale according to original shipment (order no. necessary)	51
Screw for fixing the scale	60
Zero-point screw with nut	70
Indicator cover with glass window, gasket, screws	80
Scale pointer with hub	90
Scale pointer with hub and 2 switching dials	91
Scale pointer with hub and linearization disc	92
Scale pointer with hub and linearization disc/switching dial	93
Scale pointer with hub and 2 switching dials and ES position magnet	94
1. SJ 3,5 N limit transducer with limit value indicator	110
1. SJ 3,5 SN limit transducer with limit value indicator	111
2. SJ 3,5 N limit transducer with limit value indicator	120
2. SJ 3,5 SN limit transducer with limit value indicator	121
Connection plate for 1 limit transducer with mounting parts	130
Connection plate for 2 limit transducers with mounting parts	131
Installation set for transmitter type KINAX 3W2 Ex with lever arm and mounting parts	132
Installation set transmitter type KINAX 3W2 Ex with lever arm and mounting parts and connection for a limit transducer	133
Installation set transmitter ES Ex Hart	140
Installation set transmitter ES Ex with switch (min-max)	141
Installation set transmitter ES Ex with Profibus	142

16.2.2 Complete indicator unit with 1 SJ 3,5 N limit transducer

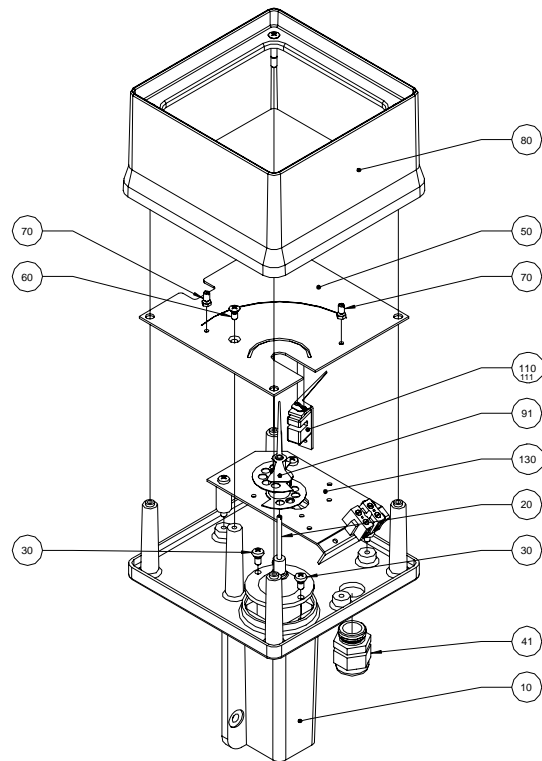

16.2.3 Complete indicator unit with 2 SJ 3,5 N limit transducers

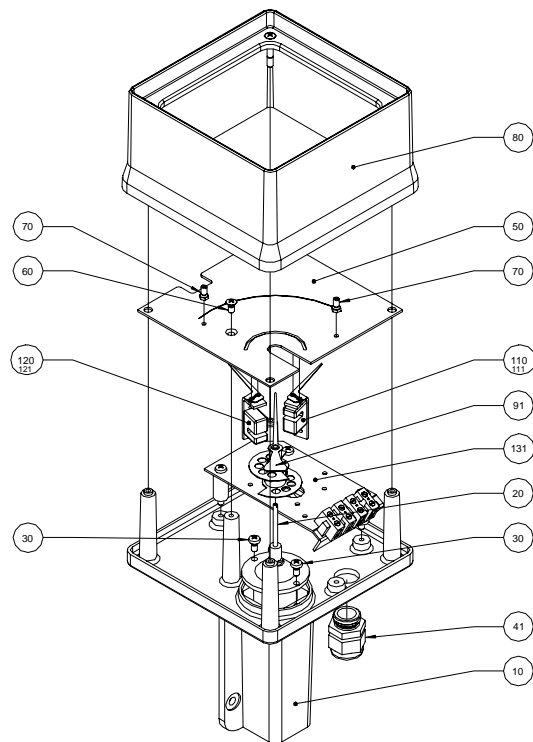

16.2.1 Complete indicator unit, local with scale

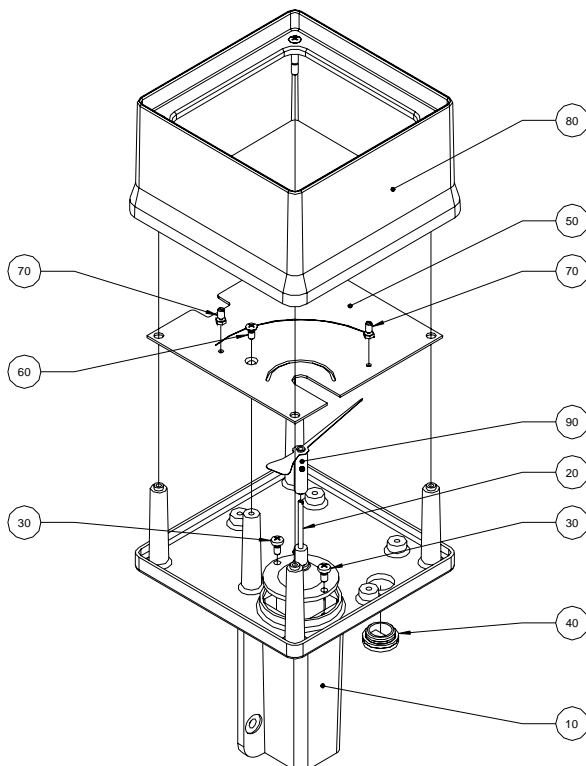

16.2.4 Complete indicator unit with E2 KINAX Ex transmitter

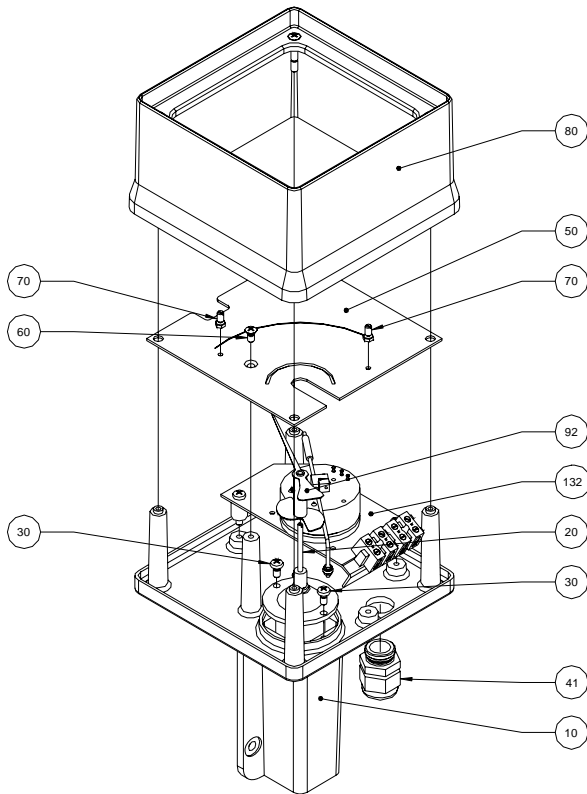

16.2.6 Indicator unit with transmitter type ES Ex HART®

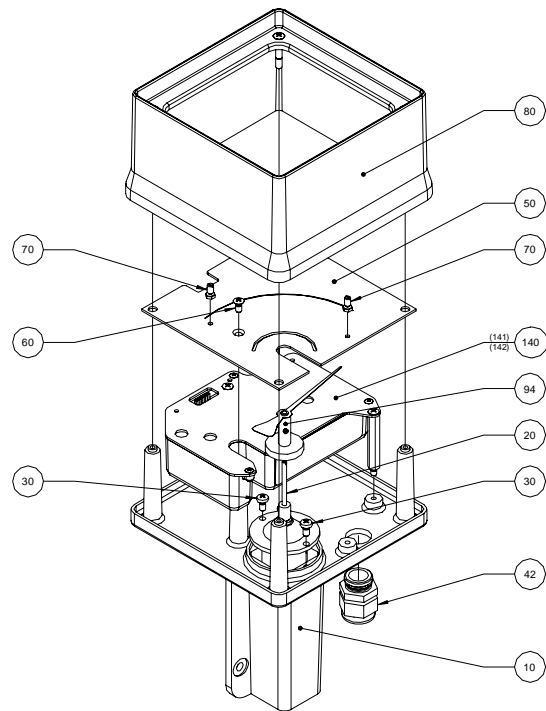

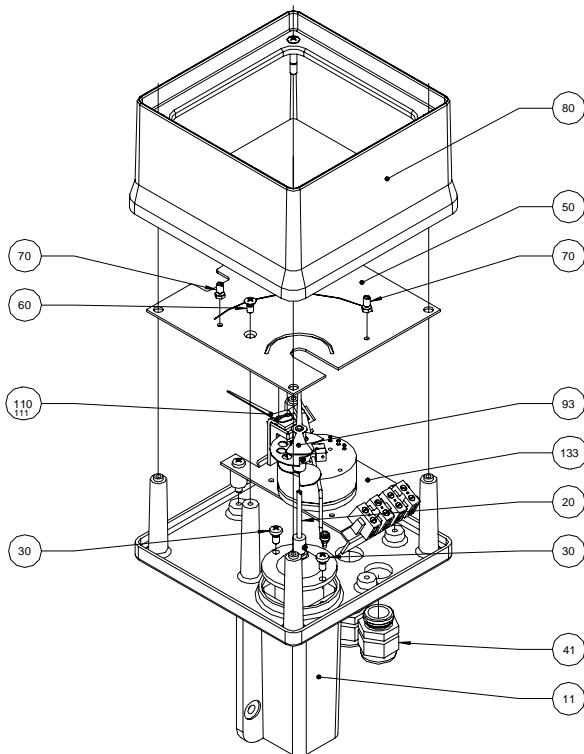

16.2.5 Complete indicator unit with E2 KINAX Ex transmitter and 1 SJ 3,5 N limit transducer



Name	Part no.
Mounting plate with 1 thread M 20 x 1.5	10
Mounting plate with 2 threads M 20 x 1.5	11
Bearing unit	20
Fixing screws for bearing unit	30
Dummy plug M 20 x 1.5	40
Cable gland	41
Cable gland	42
Scale, blank	50
Scale, product scale according to original shipment (order no. necessary)	51
Screw for fixing the scale	60
Zero-point screw with nut	70
Indicator cover with glass window, gasket, screws	80
Scale pointer with hub	90
Scale pointer with hub and 2 switching dials	91
Scale pointer with hub and linearization disc	92
Scale pointer with hub and linearization disc/switching dial	93
Scale pointer with hub and 2 switching dials and ES position magnet	94
1. SJ 3,5 N limit transducer with limit value indicator	110
1. SJ 3,5 SN limit transducer with limit value indicator	111
2. SJ 3,5 N limit transducer with limit value indicator	120
2. SJ 3,5 SN limit transducer with limit value indicator	121
Connection plate for 1 limit transducer with mounting parts	130
Connection plate for 2 limit transducers with mounting parts	131
Installation set for transmitter type KINAX 3W2 Ex with lever arm and mounting parts	132
Installation set transmitter type KINAX 3W2 Ex with lever arm and mounting parts and connection for a limit transducer	133
Installation set transmitter ES Ex Hart	140
Installation set transmitter ES Ex with switch (min-max)	141
Installation set transmitter ES Ex with PROFIBUS	142

17 EC Type Examination Certificate

<div style="display: flex; justify-content: space-between; align-items: center;">   </div> <div style="text-align: center; margin-top: 20px;"> <p>EC-Type Examination Certificate</p> <p>Appendix to</p> <p>DMT 00 ATEX E 075</p> </div> <div style="margin-top: 20px;"> <p>(1) Translation</p> <p>(2) - Directive 94/9/EC - Equipment and protective systems intended for use in potentially explosive atmospheres</p> <p>(3) DMT 00 ATEX E 075</p> <p>(4) Equipment: Electronic transmitter type ES or ES-PPA</p> <p>(5) Manufacturer: Bopp & Reuther Heinrichs Messtechnik Josef Heinrichs GmbH & Co. Messtechnik KG</p> <p>(6) Address: D 50933 Köln</p> <p>(7) The design and construction of this equipment and any acceptable variation thereto are specified in the schedule to this type examination certificate.</p> <p>(8) The certification body of Deutsche Montan Technologie GmbH, notified body no. 0158 in accordance with Article 9 of the Directive 94/9/EC of the European Parliament and the Council of 23 March 1994, certifies that this equipment has been found to comply with the Essential Health and Safety Requirements relating to the design and construction of equipment and protective systems intended for use in potentially explosive atmospheres, given in Annex II to the Directive. The examination and test results are recorded in the test and assessment report BVS PP 00.2071 EG.</p> <p>(9) The Essential Health and Safety Requirements are assured by compliance with: EN 50014:1997+A1-A2 General requirements EN 50020:1994 Intrinsic safety 'i'</p> <p>(10) If the sign "X" is placed after the certificate number, it indicates that the equipment is subject to special conditions for safe use specified in the schedule to this certificate.</p> <p>(11) This EC-Type Examination Certificate relates only to the design and construction of the specified equipment. Further requirements of Directive 94/9/EC apply to the manufacture and placing on the market of this equipment.</p> <p>(12) The marking of the equipment shall include the following: Ex II 2G EEx ia IIC T6</p> </div>	<div style="text-align: right; margin-bottom: 20px;"> <p>Signed: Jockers</p> <p>DMT-Certification body</p> </div> <div style="text-align: right; margin-bottom: 20px;"> <p>Signed: Dill</p> <p>Head of special services unit</p> </div> <div style="text-align: right; margin-bottom: 20px;"> <p>Deutsche Montan Technologie GmbH Essen, dated 31. Oktober 2000</p> </div> <div style="text-align: right; font-size: small;"> <p>page 1 of 3 to DMT 00 ATEX E 075 This certificate may only be reproduced in its entirety and without change Am Technologiepark 1, 45307 Essen, Telefon (020)172-1416, Telefax (020)172-1716</p> </div>																																																												
<p>(13) Subject and type</p> <p>(14) Electronic transmitter type ES or ES-PPA</p> <p>(15) 15.1. Subject and type Electronic transmitter type ES or ES-PPA</p> <p>15.2. Description The electronic transmitter serves for the recording of the position or angular position of a magnet at rotameters. The completely encapsulated electronic device of the transmitter is mounted in a light alloy housing together with corresponding terminals for the connection of the intrinsically safe circuits. The transmitter is provided to be installed in a housing with a min. degree of protection IP 20.</p> <p>15.3. Parameters</p> <p>15.3.1 type ES</p> <p>15.3.1.1 Input circuit (terminals 1 and 2)</p> <table border="1" style="width: 100%; border-collapse: collapse; margin-top: 10px;"> <tr> <td>U_i</td> <td>DC</td> <td>30</td> <td>V</td> </tr> <tr> <td>I_i</td> <td></td> <td>150</td> <td>mA</td> </tr> <tr> <td>P_i</td> <td></td> <td>1</td> <td>W</td> </tr> <tr> <td>L_i</td> <td></td> <td>0,24</td> <td>mH</td> </tr> <tr> <td>C_i</td> <td></td> <td>16</td> <td>nF</td> </tr> </table> <p>15.3.1.2 Binary outputs 1 and 2, potentially free optocoupler circuits (terminals 3 - 4 and 5 - 6), each</p> <table border="1" style="width: 100%; border-collapse: collapse; margin-top: 10px;"> <tr> <td>U_o</td> <td>DC</td> <td>30</td> <td>V</td> </tr> <tr> <td>I_o</td> <td></td> <td>20</td> <td>mA</td> </tr> <tr> <td>P_o</td> <td></td> <td>100</td> <td>mW</td> </tr> <tr> <td>L_o</td> <td></td> <td>4</td> <td>µH</td> </tr> <tr> <td>C_o</td> <td></td> <td>16</td> <td>nF</td> </tr> </table> <p>15.3.2 type ES-PPA Input circuit (terminals 7 and 8) for connection with a circuit in accordance with FISCO model (PTB report no. PTBW-53)</p> <table border="1" style="width: 100%; border-collapse: collapse; margin-top: 10px;"> <tr> <td>U_i</td> <td>DC</td> <td>25</td> <td>V</td> </tr> <tr> <td>I_i</td> <td></td> <td>280</td> <td>mA</td> </tr> <tr> <td>P_i</td> <td></td> <td>2</td> <td>W</td> </tr> <tr> <td>L_i</td> <td></td> <td>negligible</td> <td></td> </tr> <tr> <td>C_i</td> <td></td> <td>negligible</td> <td></td> </tr> </table> <p>15.3.3 ambient temperature range</p> <p>T_a -40 °C up to +70 °C</p>	U _i	DC	30	V	I _i		150	mA	P _i		1	W	L _i		0,24	mH	C _i		16	nF	U _o	DC	30	V	I _o		20	mA	P _o		100	mW	L _o		4	µH	C _o		16	nF	U _i	DC	25	V	I _i		280	mA	P _i		2	W	L _i		negligible		C _i		negligible		<p>page 2 of 3 to DMT 00 ATEX E 075 This certificate may only be reproduced in its entirety and without change Am Technologiepark 1, 45307 Essen, Telefon (020)172-1416, Telefax (020)172-1716</p>
U _i	DC	30	V																																																										
I _i		150	mA																																																										
P _i		1	W																																																										
L _i		0,24	mH																																																										
C _i		16	nF																																																										
U _o	DC	30	V																																																										
I _o		20	mA																																																										
P _o		100	mW																																																										
L _o		4	µH																																																										
C _o		16	nF																																																										
U _i	DC	25	V																																																										
I _i		280	mA																																																										
P _i		2	W																																																										
L _i		negligible																																																											
C _i		negligible																																																											



(1) **EC-TYPE-EXAMINATION CERTIFICATE**
(Translation)

(2) Equipment and Protective Systems Intended for Use in Potentially Explosive Atmospheres - Directive 94/9/EC

(3) EC-type-examination Certificate Number:
PTB 97 ATEX 2271

(4) Equipment: Transmitter for angular position KINAX 3W2 type 708-...
... resp. KINAX W1707 type 707-...
resp. KINAX W1706 type 706-...

(5) Manufacturer: Camille Bauer AG

(6) Address: Aargauerstrasse 7, CH-5610 Wohlen

(7) This equipment and any acceptable variation thereto are specified in the schedule to this certificate and the documents therein referred to.

(8) The Physikalisch-Technische Bundesanstalt, notified body No. 0102 in accordance with Article 9 of the Council Directive 94/9/EC of 23 March 1994, certifies that this equipment has been found to comply with the Essential Health and Safety Requirements relating to the design and construction of equipment and protective systems intended for use in potentially explosive atmospheres, given in Annex II to the Directive.

The examination and test results are recorded in the confidential report PTB Ex 97-27381.

(9) Compliance with the Essential Health and Safety Requirements has been assured by compliance with:
EN 50014:1997
EN 50020:1994

(10) If the sign "X" is placed after the certificate number, it indicates that the equipment is subject to special conditions for safe use specified in the schedule to this certificate.

(11) This EC-type-examination Certificate relates only to the design and construction of the specified equipment in accordance with Directive 94/9/EC. Further requirements of this Directive apply to the manufacture and supply of this equipment.

(12) The marking of the equipment shall include the following:



Zertifizierungsstelle Explosionsschutz
By order

Dr.-Ing. U. Johannsmeyer
Regierungsdirektor

Braunschweig, 21.01.1998

Sheet 1/3

EC-type-examination Certificates without signature and official stamp shall not be valid. The certificates may be circulated only without alteration. Extracts or alterations are subject to approval by the Physikalisch-Technische Bundesanstalt. In case of dispute, the German text shall prevail.

Physikalisch-Technische Bundesanstalt • Bundesallee 100 • D-38116 Braunschweig



(16) Test and assessment report
BVS PP 00.2071 EG as of 31. Oktober 2000

(17) Special conditions for safe use
None

We confirm the correctness of the translation from the German original.
In the case of arbitration only the German wording shall be valid and binding.

45307 Essen, dated 31.10.2000
BVS-Schu/Kn A 200000463

Deutsche Montan Technologie GmbH

DMT-Certification body

Head of special services unit



(13) **SCHEDULE**
 (14) **EC-TYPE-EXAMINATION CERTIFICATE No. PTB 97 ATEX 2271**

(15) Description of equipment

The angular position transmitter KINAX 3W2 of type 708-..., KINAX WT 707 of type WT 707-... and KINAX WT 706 of type WT 706-... convert the angular position of a shaft contactlessly to a proportional electrical output signal.

A variation of the shaft position effects a variation of a capacitance, which is converted to a proportional current alteration by the downstream electronics.

The ranges of the ambient temperature dependent on the temperature class are shown in the following table.

Minimum ambient temperature	Maximum ambient temperature	Temperature class
-40 °C	60 °C	T 6
-40 °C	75 °C	T 5

Electrical data

Supply- and measuring output.....type of protection Intrinsic Safety EEx ia IIC for connection to a certified intrinsically safe circuit only.

Maximum values: $U_i = 30 \text{ V}$
 $I_i = 160 \text{ mA}$
 $P_i = 1 \text{ W}$

Effective internal capacitance: $C_i \leq 10 \text{ nF}$
 The effective internal inductance is negligibly small.

The transmitter for angular position KINAX 3W2 of type 708-... must be mounted into a housing which meets the requirement of a degree of protection IP 20 according to IEC 529.

Since the angular position transmitters KINAX WT 707 of type WT 707-... and KINAX WT 706 of type WT 706-... meet the requirements of a degree of protection IP 20 according to IEC 529 mounting of these variants into an additional housing is not necessary.

sheet 2/3

EC-type-examination Certificates without signature and official stamp shall not be valid. The certificates may be circulated only without alteration. Extracts or alterations are subject to approval by the Physikalisch-Technische Bundesanstalt. In case of dispute, the German text shall prevail.

Physikalisch-Technische Bundesanstalt • Bundesallee 100 • D-38116 Braunschweig



SCHEDULE TO EC-TYPE-EXAMINATION CERTIFICATE PTB 97 ATEX 2271

(16) Report PTB Ex 97-27381

(17) Special conditions for safe use
 not applicable

(18) Essential health and safety requirements
 met by standards

Braunschweig, 21.01.1998

Zertifizierungsstelle Explosionschutz
 By order



J. U. Johannsmeyer
 Dr.-Ing. U. Johannsmeyer
 Regierungsdirektor

Sheet 3/3

EC-type-examination Certificates without signature and official stamp shall not be valid. The certificates may be circulated only without alteration. Extracts or alterations are subject to approval by the Physikalisch-Technische Bundesanstalt. In case of dispute, the German text shall prevail.

Physikalisch-Technische Bundesanstalt • Bundesallee 100 • D-38116 Braunschweig



EC-TYPE-EXAMINATION CERTIFICATE
(Translation)



- (1) Equipment and Protective Systems Intended for Use in Potentially Explosive Atmospheres - Directive 94/9/EC
- (2) EC-type-examination Certificate Number:
PTB 99 ATEX 2219 X
- (3) Equipment: Slot-type initiators types SJ... and SC...
- (4) Manufacturer: Peppert + Fuchs GmbH
- (5) Address: D-68307 Mannheim

- (6) This equipment and any acceptable variation thereto are specified in the schedule to this certificate and the documents therein referred to.
- (7) The Physikalisch-Technische Bundesanstalt, notified body No. 0102 in accordance with Article 9 of the Council Directive 94/9/EC of 23 March 1994, certifies that this equipment has been found to comply with the Essential Health and Safety Requirements relating to the design and construction of equipment and protective systems intended for use in potentially explosive atmospheres, given in Annex II to the Directive.
- (8) The examination and test results are recorded in the confidential report PTB Ex 99-29175.
- (9) Compliance with the Essential Health and Safety Requirements has been assured by compliance with:
EN 50014:1997
EN 50020:1994
- (10) If the sign "X" is placed after the certificate number, it indicates that the equipment is subject to special conditions for safe use specified in the schedule to this certificate.
- (11) This EC-type-examination Certificate relates only to the design and construction of the specified equipment in accordance with Directive 94/9/EC. Further requirements of this Directive apply to the manufacture and supply of this equipment.
- (12) The marking of the equipment shall include the following:

II 2 G EEx ia IIC T6
 Zertifizierungsstelle Explosionsschutz
 By order:
 Braunschweig, December 22, 1999



Dr.-Ing. U. Johannsmeyer
 Regierungsdirektor

sheet 1/3

EC-type-examination Certificates without signature and official stamp shall not be valid. The certificates may be circulated only without alteration. Extracts or alterations are subject to approval by the Physikalisch-Technische Bundesanstalt. In case of dispute, the German text shall prevail.

Physikalisch-Technische Bundesanstalt • Bundesallee 100 • D-38116 Braunschweig

SCHEDULE
EC-TYPE-EXAMINATION CERTIFICATE PTB 99 ATEX 2219 X

- (13) **Description of equipment**
The slot-type initiators of types SJ... and SC... are used to convert displacements into electrical signals.
- (14) The slot-type initiators may be operated with intrinsically safe circuits certified for categories and explosion groups [EEx ia] IIC or IIB resp. [EEx ib] IIC or IIB. The category as well as the explosion group of the intrinsically safe slot-type initiators depends on the connected supplying intrinsically safe circuit.

Electrical data

Evaluation and supply circuit..... type of protection Intrinsic Safety EEx ia IIC/IIB resp. EEx ib IIC/IIB only for connection to certified intrinsically safe circuits
 Maximum values:

type 1	type 2	type 3	type 4
U _i = 16 V	U _i = 16 V	U _i = 16 V	U _i = 16 V
I _i = 25 mA	I _i = 25 mA	I _i = 52 mA	I _i = 76 mA
P _i = 34 mW	P _i = 64 mW	P _i = 169 mW	P _i = 242 mW

The assignment of the type of the connected circuit to the maximum permissible ambient temperature and the temperature class as well as the effective internal reactances for the individual types of slot-type initiators are shown in the table:

sheet 2/3

EC-type-examination Certificates without signature and official stamp shall not be valid. The certificates may be circulated only without alteration. Extracts or alterations are subject to approval by the Physikalisch-Technische Bundesanstalt. In case of dispute, the German text shall prevail.

Physikalisch-Technische Bundesanstalt • Bundesallee 100 • D-38116 Braunschweig

Physikalisch-Technische Bundesanstalt



Braunschweig und Berlin

SCHEDULE TO EC-TYPE-EXAMINATION CERTIFICATE PTB 99 ATEX 2219 X

types	C _i [nF]	L _i [μH]	type 1			type 2			type 3			type 4		
			maximum permissible ambient temperature in °C for application in temperature class											
			T6	T5	T4-T1	T6	T5	T4-T1	T6	T5	T4-T1	T6	T5	T4-T1
SC2-N0...	150	150	72	87	100	65	80	100	40	55	75	23	38	54
SC3,5-N0-Y...	150	150	72	87	100	65	80	100	40	55	75	23	38	54
SC3,5...-N0...	150	150	73	88	100	66	81	100	45	60	89	30	45	74
SJ1,8-N-Y...	30	100	73	88	100	67	82	100	45	60	78	30	45	57
SJ2,2-N...	30	100	73	88	100	67	82	100	45	60	78	30	45	57
SJ2-N...	30	100	73	88	100	67	82	100	45	60	78	30	45	57
SJ3,5...-N...	50	250	73	88	100	66	81	100	45	60	89	30	45	74
SJ3,5-H...	50	250	73	88	100	66	81	100	45	60	89	30	45	74
SJ5...-N...	50	250	73	88	100	66	81	100	45	60	89	30	45	74
SJ5-K...	50	550	72	87	100	66	81	100	42	57	82	26	41	63
SJ10-N...	50	1000	72	87	100	66	81	100	42	57	82	26	41	63
SJ15-N...	150	1200	72	87	100	66	81	100	42	57	82	26	41	63
SJ30-N...	150	1250	72	87	100	66	81	100	42	57	82	26	41	63

(16) Test report PTB Ex 99-29175

(17) Special conditions for safe use

- For the application within a temperature range of -60°C to -20 °C the slot-type initiators of types SJ... and SC... must be protected against damage due to impact by mounting into an additional housing.
- The connection facilities of the slot-type initiators of types SJ... and SC... shall be installed as such that at least a degree of protection of IP20 according to IEC-publication 60529:1989 is met.
- The assignment of the type of the connected circuit to the maximum permissible ambient temperature and the temperature class as well as the effective internal reactances for the individual types of slot-type initiators is shown in the table given under item (15) of this EC-type-examination certificate..
- Inadmissible electrostatic charge of the plastic housing of the slot-type initiators of type SJ30-N..., has to be avoided (warning label on the device).

(18) Essential health and safety requirements

Met by the standards mentioned above

Zertifizierungsstelle Explosionsschutz
By order:

Dr.-Ing. U. Johannsmeyer
Regierungsdirektor



Braunschweig, August 10, 1999

sheet 3/3

EC-type-examination Certificates without signatures and official stamp shall not be valid. The certificates may be circulated only without alteration. Extracts or alterations are subject to approval by the Physikalisch-Technische Bundesanstalt. In case of dispute, the German text shall prevail.

Physikalisch-Technische Bundesanstalt • Bundesallee 100 • D-38116 Braunschweig

