

Glass tube flowmeters Series 6000



Variable area flowmeter for liquids and gases

- Easy installation
- Local indication by means of direct reading
- Low pressure drop
- Scales directly in l/h, m³/h, kg/h, l/min, %, etc.
- Plastic protection against accidental breakage of the glass tube
- Flow rate:
 - Water: 2.5 l/h ... 50 m³/h
 - Air: 45 NI/h ... 1500 Nm³/h
- Accuracy: 1.6% ($\alpha_G=50\%$)
- Connections:
 - BSP or NPT threaded connections: 1/2" ... 3"
 - EN 1092-1 or ANSI flanges: DN15 ... DN80
Other flange standards on request
 - Sanitary couplings according to ISO 2852, SMS 1145, DIN 11851, TRI-CLAMP®
- Materials:
 - Measuring tube: borosilicate glass
 - Frame: galvanized and coated steel, EN 1.4301 (AISI 304)
 - Protection shield: metacrylate
 - Wetted parts: galvanized and coated steel, EN 1.4404 (AISI 316L), PVC, PP, PTFE, PVDF
 - Float: EN 1.4404 (SS 316L), PVC, PP, PTFE, PVDF
- Local indication
- Options:
 - 1 or 2 limit switches
 - Electronic transmitter with 4-20 mA analog output for safe or hazardous area (Ex ia IIC T6 protection, ATEX certified). HART, FIELDBUS & PROFIBUS protocols available on request



HART
COMMUNICATION PROTOCOL

Working principle

The 6000 series flowmeters work according to variable area principle, which is obtained by a float that moves inside a borosilicate glass tapered tube.

The fluid flows up through the tapered tube forcing the float to a position with sufficient free area to enable the flow to pass, where there is an equilibrium of forces:

- E = force of the fluid flow
 - Pf = weight of the float
 - Af = free area of flow
- (Al = Ac, tube area, - Af, float area)

Each position of the float corresponds to a value of flow rate.

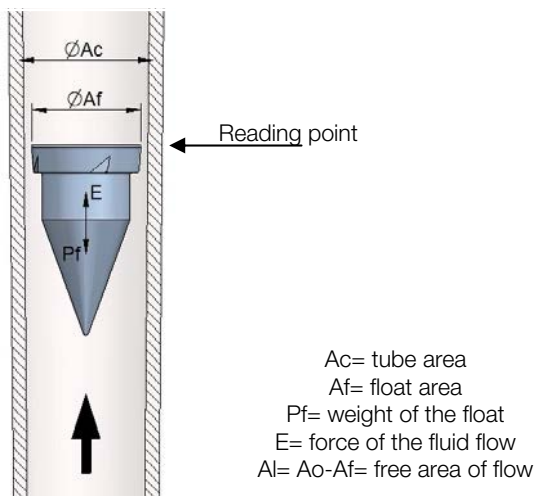

Applications

- Water treatment
- Heating-cooling circuits
- Laboratories
- Control of gas burners
- Chemical industry and treatment ovens
- Flow rigs

Models

- 6001 BSP threaded connection. Others on request
 - 6002 EN 1092-1 flange connection. Others on request
 - 6009 PVC solvent socket or EN 1.4404 for welding
 - 6011 DIN 11851 sanitary coupling
 - 6013 CLAMP ISO 2852 sanitary coupling
 - 6015 SMS 1145 sanitary coupling
-
- 6000-Fe all components in galvanized and coated steel
 - 6000-SS wetted parts in EN 1.4404 (AISI 316L). Other components in galvanized and coated steel
 - 6000-FULLY SS all components in EN 1.4404 (AISI 316L), except frame in EN 1.4301 (AISI 304)

- 6000-PVC wetted parts in PVC. Other components in galvanized and coated steel
- 6000-PP wetted parts in PP. Other components in galvanized and coated steel
- 6000-PTFE wetted parts in PTFE. Other components in galvanized and coated steel
- 6000-PVDF wetted parts in PVDF. Other components in galvanized and coated steel

Technical data

- Accuracy, acc. to VDI/VDE 3513 sheet 2 ($q_G=50\%$): 1.6%
- Direct scales in engineering units or %
- Scale range: 10:1
- Fluid temperature: -20°C ... +80°C
- Ambient temperature: -20°C ... +60°C
- Working pressure: from 5 to 15 bar max., depending on flowmeter size
- Connections:
 - BSP or NPT threaded connections: 1/2" ... 3"
 - EN 1092-1 or ANSI flanges: DN15 ... DN80
Other standards on request
 - Sanitary couplings according to ISO 2852, SMS 1145, DIN 11851, TRI-CLAMP®
- Measuring tube length: 300 mm

Operation

- Vertical with upwards flow

Limit switches and transmitters

- 60-AMM1 ... 2: 1 or 2 adjustable micro-switches (available from 40-400 l/h)
- 60-AMD1 ... 2: 1 or 2 adjustable inductive switches (available from 40-400 l/h)
- PT-AMR1 ... 2: 1 or 2 adjustable reed switches (available from 10-100 l/h)
- 60-TMUR: 4-20 mA transmitter (18 points), 220 VAC 4-wire system with remote converter (24 VDC 2-wire system and Ex intrinsically safe version on request) (available from 40-400 l/h)

Float types

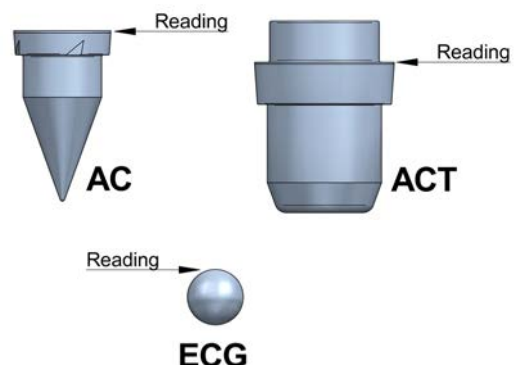

Glass tube flowmeters

Series 6000

Materials

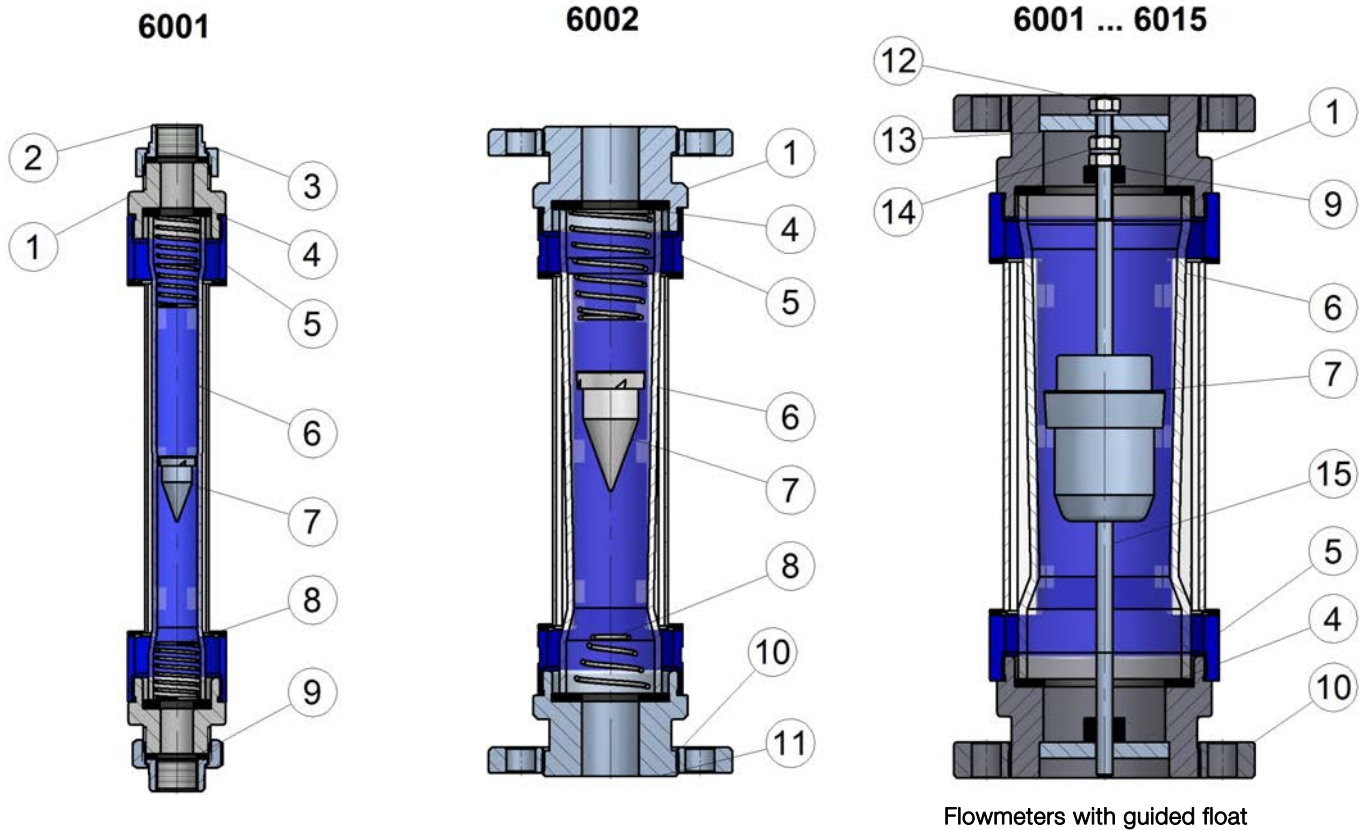

Flowmeters with guided float

N°	Description	Materials				
		6000-Fe	6000-SS	6000-FULLY SS	6000-PVC / PP	6000-PTFE
1	End piece	Steel	AISI 316L	AISI 316L	PVC / PP	Steel + PTFE
2	End connector	Steel	AISI 316L	AISI 316L	PVC / PP	PTFE
3	Union nut	Steel	Steel	AISI 316L	PVC / PP	Steel
4	Frame gasket	NBR	NBR	NBR	NBR	PTFE+NBR
5	Frame	Steel	Steel	AISI 304	Steel	Steel
6	Measuring tube	Borosilicate glass				
7	Float *	AISI 316L / Aluminium	AISI 316L / Aluminium	AISI 316L / Aluminium	AISI 316L / Aluminium / PVDF-Pb / PVC-Pb / PP-Pb	PTFE-Pb
8	Springs / Stops	AISI 302	AISI 302	AISI 302	AISI 302 / PVDF	PTFE
9	Connector gasket	NBR	NBR	NBR	NBR	PTFE+NBR
10	Flange	Steel	Steel / AISI 316L	AISI 316L	Steel / PVC / PP	Steel
11	Flange seat	Steel	AISI 316L	AISI 316L	PVC / PP	PTFE
12	Nut	AISI 316	AISI 316	AISI 316	AISI 316, PVC, PP	PTFE
13	Centering ring	AISI 316 (PP, PVDF) **	AISI 316 (PP, PVDF) **	AISI 316 (PP, PVDF) **	AISI 316, PVC, PP	PTFE
14	Washer	AISI 316	AISI 316	AISI 316	AISI 316, PVC, PP	PTFE
15	Guide	AISI 316	AISI 316	AISI 316	AISI 316, PVC, PP	PTFE

In all cases, galvanized and coated steel - Other gasket materials on request: VITON®, EPDM

* Only the most usual are shown. Float material might change depending on application requirements.

** For low flows.

Dimensions

Models 6001 (BSP / NPT) - 6009 (socket / welding)

R" NPT	DN	6001				6009	
		A	B	L	Weight kg	A	Weight kg
1/2"	15	60	15	410	2	49	1
3/4"	20	60	15	415	2	49 / 61	1 / 1.3
1"	25	75	20	425	3	61 / 91	1.3 / 3
1 1/2"	40	105	20	445	6	91	3
2"	50	120	25	460	10	105	4.5
2 1/2"	65	150	25	505	13	130	7.5
3"	80	150	30	510	17	130	7.5

Model 6002 (EN 1092-1)

DN	D	k	g	B	l x n°	L	Weight kg
15	95	65	45	14	14x4	380	2.5
20	105	75	58	14	14x4	380	3.3
25	115	85	68	16	14x4	390	4.8
40	150	110	88	16	18x4	400	8
50	165	125	102	18	18x4	410	11
65	185	145	122	18	18x4	420	15.3
80	200	160	138	20	18x4	420	19.3

Model 6002 (ANSI 150#)

DN	D	k	g	B	l x n°	L	Weight kg
1/2"	88.9	60.3	34.9	11.1	15.9x4	380	2.5
3/4"	98.4	69.8	42.9	12.7	15.9x4	380	3.3
1"	107.9	79.4	50.8	14.3	15.9x4	390	4.8
1 1/2"	127.0	98.4	73.0	17.5	15.9x4	400	8
2"	152.4	120.6	92.1	19.1	19x4	410	11
2 1/2"	177.8	139.7	104.8	22.2	19x4	420	15.3
3"	190.5	152.4	127.0	23.8	19x4	420	19.3

Model 6011 (DIN 11851)

NW	15(M1)	25(M2)	40(M3)	50(M4)	65(M5)	80(M5)	100(M5)
Rd	Rd 34	Rd 52	Rd 65	Rd 78	Rd 95	Rd 110	Rd 130
Ø C7	x 1/8"	x 1/6"	x 1/6"	x 1/6"	x 1/6"	x 1/4"	x 1/4"
Ø C6	17	24.8	35.6	45.8	67	82.8	100
Ø d2	21.3	30	42	51	73	88.9	108
L	395	400	405	425	435	480	480

Model 6013 (CLAMP ISO 2852:1993)

NW	15(M1)	25(M2)	40(M3)	50(M4)	65(M5)	80(M5)	100(M5)
Ø C7	34	50.5	50.5	64	91	106	130
Ø C6	17	24.8	35.6	45.8	67	82.8	100
Ø d2	21.3	30	42	51	73	88.9	108
L	395	400	405	425	435	480	480

All dimensions in mm

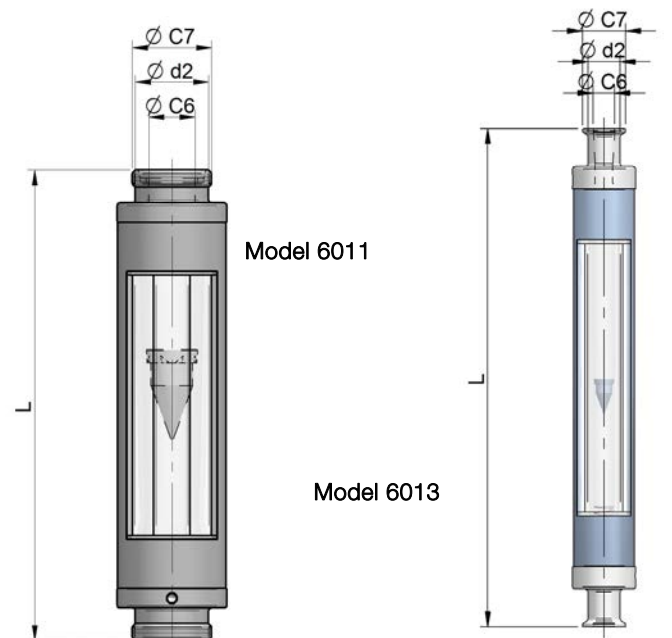
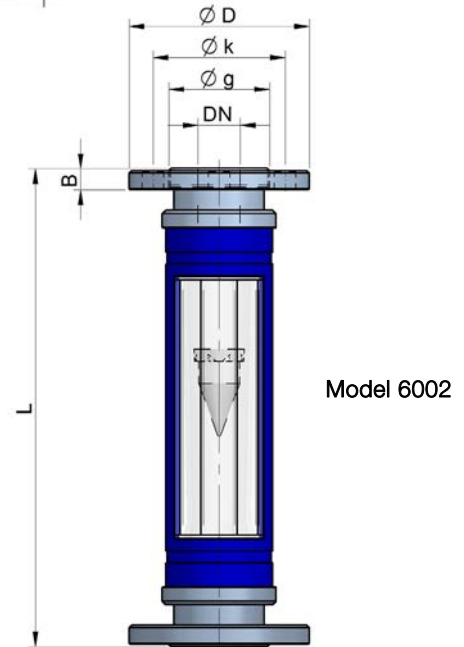
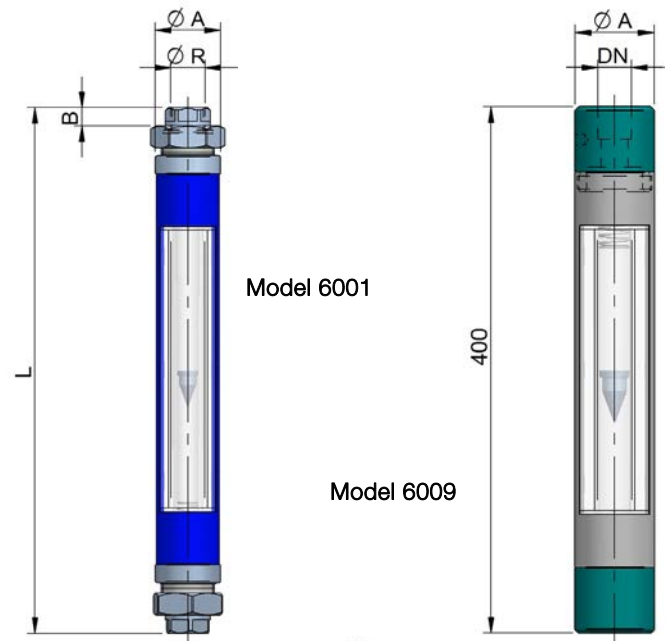

Glass tube flowmeters

Series 6000

Model 6015 (SMS 1145)

NW	15(M1)	25(M2)	40(M3)	50(M4)	65(M5)	80(M5)	100(M5)
Ø C7	Rd	Rd	Rd	Rd	Rd	Rd	Rd
	40-6	48-6	60-6	70-6	85-6	120-4	140-4
Ø C6	22.5	29.4	35.5	48.5	60.5	86	104
Ø d2	25	42	51	63,5	73	93	108
L	395	400	405	425	435	480	480

Model 6015

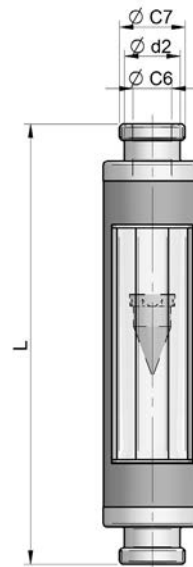

All dimensions in mm

Flow ranges

Model N°	Flow scales EN 1.4404 float 7.95 g/cm³			Flow scales Aluminium float 2.85 g/cm³		Max. pressure bar	Frame n°	R" (DN)
	l/h water	Nm³/h air 1.013 bar abs 20°C	ΔP mbar	Nm³/h air 1.013 bar abs 20°C	ΔP mbar			
C31-00251	2.5-25	0.07-0.7		0.04-0.4				
C31-00401	4-40	0.11-1.1	6	0.07-0.7	2			
C31-00601	6-60	0.18-1.8		0.1-1			1	½" (DN15)
C32-01001	10-100	0.3-3		0.17-1.7				¾" (DN20)
C32-01601	16-160	0.45-4.5	9	0.25-2.5	4	15		
C32-02501	25-250	0.7-7		0.4-4				
C33-04001	40-400	1.1-11		0.7-7				
C33-06301	60-630	1.8-18	12	1.1-11	5		2	¾" (DN20)
C33-10001	100-1000	3-30		1.8-18				1" (DN25)
C34-16001	160-1600	4.5-45	18	2.5-25	8	10	3.1	
C34-25001	250-2500	7-70		5-45				1 ½" (DN40)
C35-40001	400-4000	11-110	23	7-70	10	8	3.2	
C35-63001	500-6300	18-180		10-110				
C36-M0101	1000-10000	30-300	30	20-180	12	6	4	2" (DN50)
C36-M0141	2000-14000	120-420		40-250				
C37-M0161	1600-16000	45-450		30-290				
C37-M0201	2000-20000	60-600		40-360				
C37-M0251	2500-25000	70-700		50-460				2 ½" (DN65)
C37-M0301	3000-30000	90-900	40	60-550	17	5	5	3" (DN80)
C37-M0401	6000-40000	180-1200		110-730				
C37-M0501	8000-50000	250-1500		170-920				

Model N°	AC float EN 1.4404 float 7,95 g/cm³			ECG float				Max. pressure bar	R" (DN)
	l/h water	NI/h air 1.013 bar abs 20°C	ΔP mbar	Glass float 2.60 g/cm³		Plastic float 1.30 g/cm³			
				l/h water	NI/h air 1.013 bar abs 20°C	NI/h air 1.013 bar abs 20°C	ΔP mbar		
C30-00251	2.5-25	70-700	3	1-10	40-400	15-150	2	15	½"
C30-00401	4-40	120-1200		1.6-16	70-700	25-250			(DN15)

Flow rate equivalent curves water-liquids (with different density and viscosity)

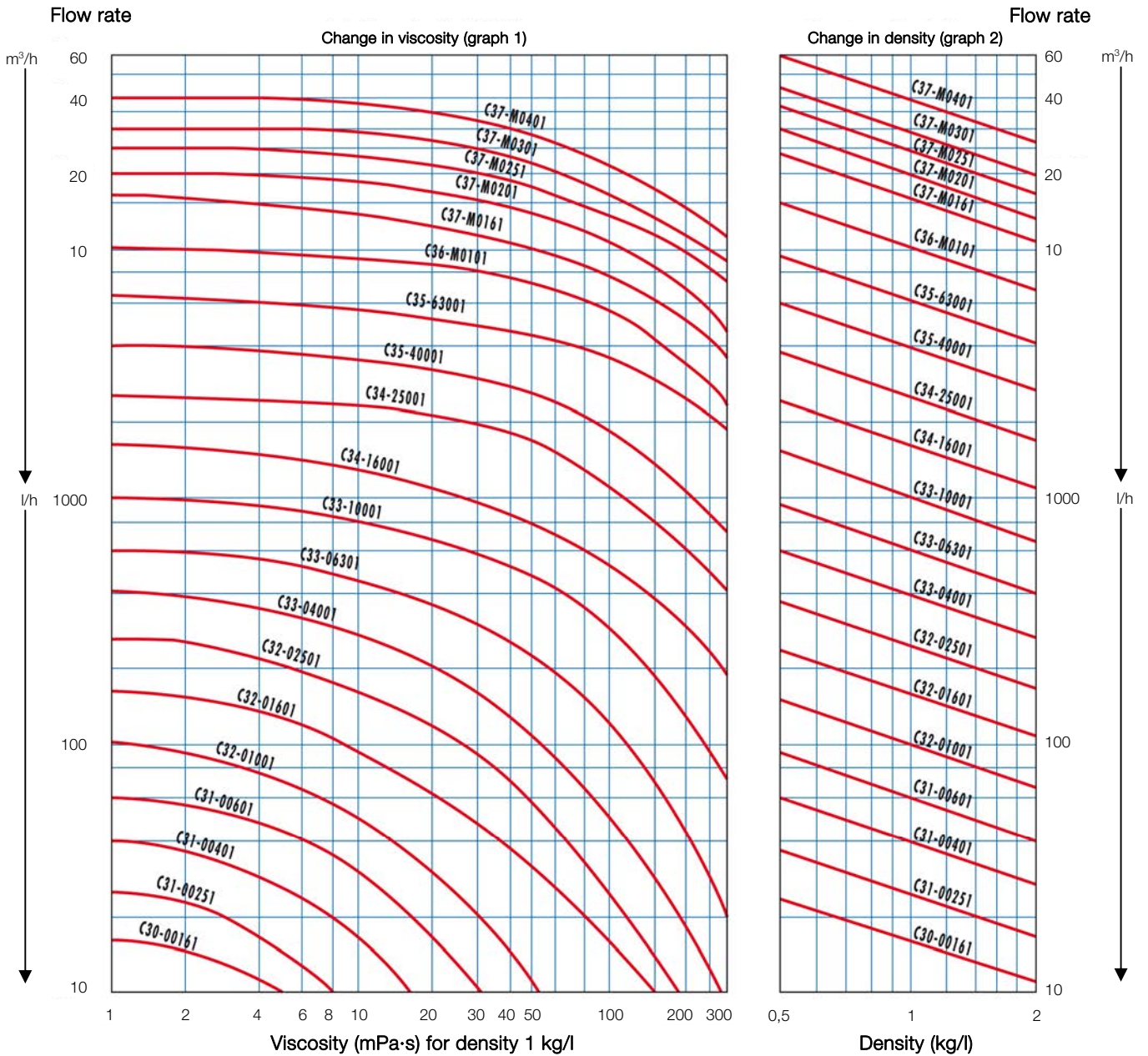

N° 1. Changes in density (graph 2)

Required flow rate 1000 l/h, density 1.4 kg/l. Enter the graph at the 1000 l/h point. Move horizontally across to applicable flow tube line (C313-1000), travel the inclined line to the point of the density of the fluid (1.4 kg/l). Travel horizontally to the vertical axis and read the equivalent flow scale 800 l/h.

N° 2. Changes in viscosity (graph 1)

Required flow rate 1000 l/h, viscosity 50 mPa·s. Enter the graph at the viscosity value and travel vertically to the point where it cuts the horizontal line at 1000 l/h. This point determines the tube selection and if it coincides with one of the curves, it is the value of maximum flow.

If the point lies between two curves, it is optional to select:

- Lower curve:

Move down by the 50 mPa·s curve until the lower curve, then horizontally to the l/h scale on the left. The maximum flow rate value is obtained with C314-1600 tube. In this case, maximum flow rate is 800 l/h.

- Upper curve:

Move up by the 50 mPa·s curve until the upper curve, then horizontally to the l/h scale on the left. The maximum flow rate value is obtained with C314-2500 tube. In this case, maximum flow rate is 1800 l/h.

N° 3. Changes in viscosity and density (graph 1 & 2)

Follow example n° 2 first and then n° 1.

Limit switches

Adjustable limit switch PT-AMR

(Flow rate from 10-100 l/h water and equivalent air ranges. AISI 304 frame is required for flow ranges 10-100, 16-160 and 25-250 l/h water and equivalent air ranges)

Bi-stable SPST reed switch, actuated by a magnet inside the float and mounted in a PVC enclosure.

- PT-AMR1 ... 2: 1 ... 2 adjustable limit switches
- Contact rating: 0.5 A / 250 V / 12 VA
- Hysteresis: $\pm 5\%$ of full scale value
- Ambient temperature: $-25^{\circ}\text{C} \dots +80^{\circ}\text{C}$
- DIN 43650-A connector, PG9 cable gland
- Suitable for hazardous area, considered as "Simple apparatus"

Frame	DN	B1
1	15 ... 20	48
2	20 ... 25	51.50
3.1	40	61
3.2	40	67.50
4	50	80
5	65 ... 80	94

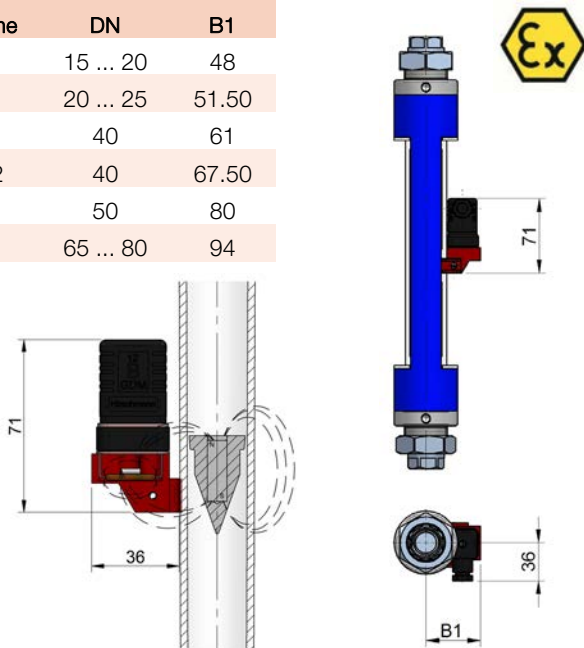

Adjustable limit switch 60-AMM

(Flow rate from 40-400 l/h water and equivalent air ranges)

Electrical micro-switch, mounted in an aluminium housing, actuated by a magnet inside the float.

- 60-AMM1 ... 2: 1 ... 2 adjustable limit switches
- Contact rating: 3(1) A, 250 V (VDE/CEE)
- Hysteresis: $\pm 10\%$ of full scale value
- Ambient temperature: $-25^{\circ}\text{C} \dots +80^{\circ}\text{C}$
- Mechanical life: 10^7 operations
- Suitable for hazardous area, considered as "Simple apparatus"

Frame	DN	B1
1	15 ... 20	90
2	20 ... 25	96
3.1	40	111
3.2	40	111
4	50	117
5	65 ... 80	130

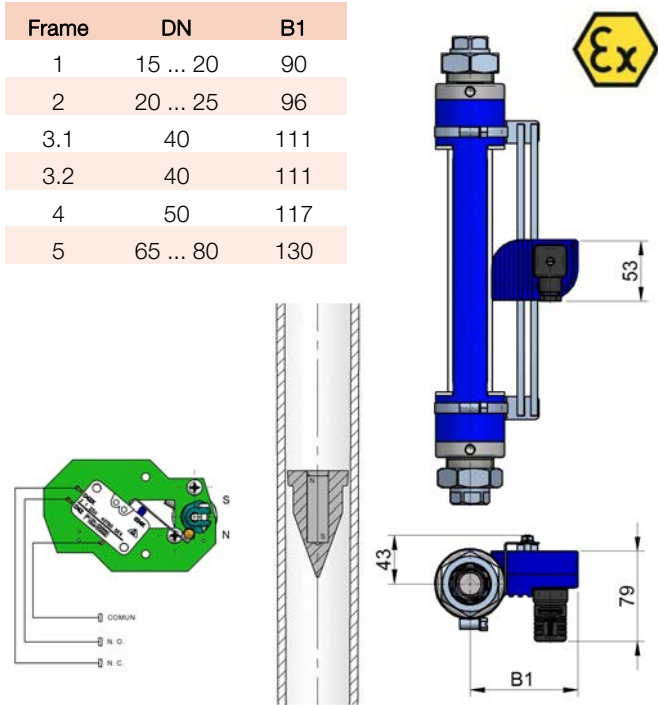

Adjustable limit switch 60-AMD

(Flow rate from 40-400 l/h water and equivalent air ranges)

NAMUR (EN 60947-5-6) 3.5 mm slot type inductive detector activated by vane, mounted in the indicator housing.

- 60-AMD1 ... 2: 1 ... 2 adjustable limit switches
- Power supply: 8 VDC
- Ambient temperature: $-25^{\circ}\text{C} \dots +70^{\circ}\text{C}$
- ATEX certificate Ex ia IIC T4...T6 Ga / Ex ia IIIC T85°C Da

Control relay (on request)

NAMUR (EN 60947-5-6) for 1 or 2 inductive detectors.

- Power supply: 24 ... 253 VAC 50-60 Hz / 24 ... 300 VDC
- Input: NAMUR Ex ia IIC
- Output: 1 or 2 relay contacts
- Output rating: 2 A 250 VAC 100 VA / 1 A 24 VDC
- Ambient temperature: $-25^{\circ}\text{C} \dots +70^{\circ}\text{C}$

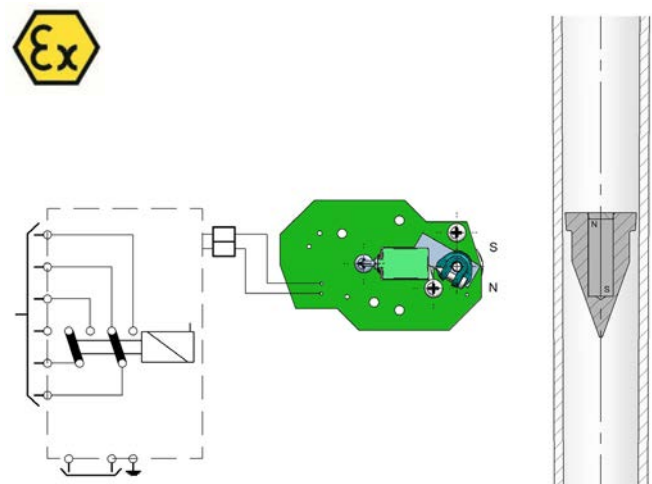

Dimensions identical to 60-AMM

All dimensions in mm

Adjustable limit switch 60-AMO

(Flow rate up to 25-250 l/h water and equivalent air ranges)

Infrared optical switch, actuated by the float when crossing the beam, mounted in a plastic enclosure and supplied together with control relay in an aluminium housing. Suitable for all float materials except glass.

- 60-AMO1 ... 2: 1 ... 2 adjustable limit switches
- Contact rating: 1A 220 VAC / 50Hz
- Hysteresis: $\pm 5\%$ of full scale value
- Ambient temperature: -10°C ... $+80^{\circ}\text{C}$
- Power supply: 220 VAC / 50Hz or 24 VDC

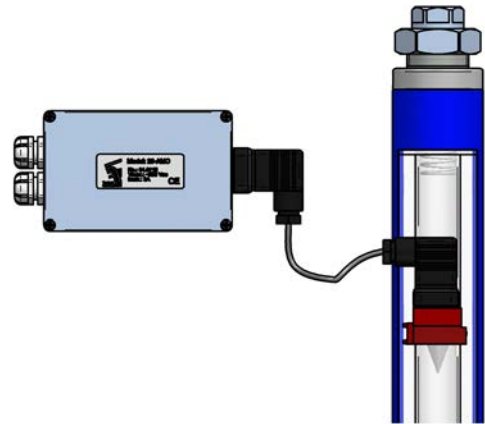

Transmitters

Transmitter 60-TMUR 0 ... 4-20 mA

(Flow rate from 40-400 l/h water equivalent air ranges)

The TMUR electronic transmitter consists of a reed chain which is mounted inside a plastic enclosure IP65 rated. Installation on the flowmeter frame by means of two screws or SS straps. By means of a converter, the resistance signal is converted in to current (0 ... 4-20 mA).

Technical data TMUR

- Working temperature: $+5^{\circ}\text{C}$... $+60^{\circ}\text{C}$
- Resolution: 10 mm

4-wire system

TR420 converter technical data

- DIN 46277 rail mounted
- Power supply: 24, 110, 230, 240 VAC 50/60 Hz / 24 VDC
- Consumption: <1 VA
- Outputs: 0-20 mA, 4-20 mA, 0-5 V, 0-10 V, 1-5 V, 2-10 V

2-wire system (on request)

- 24VDC power supply
- Suitable for hazardous area with ATEX certification
- HART, Profibus or Fieldbus protocols



- Power supply:
 - 8 ... 35 VDC, safe area version
 - 8 ... 30 VDC, hazardous area version
- Consumption: 0,8 W
- Output: 4-20 mA
- Hazardous area version ATEX certified Ex ia IIC T6

For 2-wire system, the electrical connection is made directly on terminals mounted in an IP67 housing, compact mounted on the reed chain.

DN	A
15 ... 20	80
20 ... 25	85
40	101
50	107
65 ... 80	120

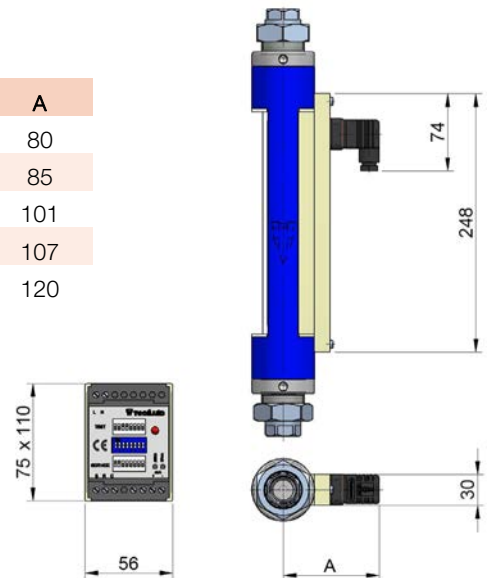

Tecfluid S.A.

Narcis Monturiol 33
08960 Sant Just Desvern
Barcelona
Tel: +34 93 372 45 11
Fax: +34 93 473 44 49
tecfluid@tecfluid.com
www.tecfluid.com

Quality Management System ISO 9001 certified by **Applus[®]**

Pressure Equipment Directive 97/23/CE certified by **Lloyds Register**

ATEX European Directive 94/9/CE certified by



HART[®] is a registered trademark of HART Communication Foundation